



# Historic Bridge Management Plan for the Old River Navigation Canal Bridge

Recall Number: 054900

Structure Number: 61391770105911

Parish: Pointe Coupee

Route: LA 15

Crossing Description: Old River Navigation Canal



Prepared for

**Louisiana Department of  
Transportation and  
Development**

Prepared by

**Mead  
& Hunt**

[www.meadhunt.com](http://www.meadhunt.com)

March 2017

**THIS PAGE INTENTIONALLY LEFT BLANK**

## Table of Contents

	Page
<b>Executive Summary .....</b>	<b>1</b>
<b>1. Introduction .....</b>	<b>3</b>
<b>2. Location Map .....</b>	<b>5</b>
<b>3. Historic Data .....</b>	<b>7</b>
A. Identifying information .....	7
B. Description of bridge .....	7
C. History and significance .....	9
D. Character-defining features .....	11
<b>4. Engineering Data.....</b>	<b>17</b>
A. Existing conditions .....	17
(1) Structural observations .....	17
(2) Non-structural observations .....	18
(3) Serviceability observations.....	18
B. Sources of information.....	19
<b>5. Recommendations .....</b>	<b>31</b>
A. Preventative maintenance .....	32
B. Rehabilitation .....	32
C. Identification of any anticipated design exceptions .....	33

### Appendices

- A Historic Inventory Form
- B Select Plan Sheets
- C 2014 Maintenance Agreement between the USACE and LADOTD

**THIS PAGE INTENTIONALLY LEFT BLANK**

## Executive Summary

The Old River Navigation Canal Bridge (Old River Bridge) (Recall No. 054900) is located in Pointe Coupee Parish, Louisiana, and is owned by the State of Louisiana. The bridge was completed in 1965. The bridge was determined eligible for the National Register of Historic Places (National Register) in 2013. It is significant as a movable bridge that features an important variation within the vertical lift type; namely, the bridge features centrally located drive machinery that operates the four sheaves. In addition, the bridge is significant for its importance to both conservation and transportation as a vertical lift structure over the Old River Navigation Canal, which was constructed to conserve the flow of the Mississippi River while allowing for boat traffic to flow between the Mississippi River and the Atchafalaya and Red Rivers. The construction of the bridge allowed vehicular traffic to cross the Old River Canal over the navigation lock. The bridge and canal are associated with two spillways (related bridges are Recall Nos. F15771 and F15321) that are parts of the Old River Control Structure. This evaluation addresses only the highway bridge over the navigation canal and not the overall complex.

The bridge carries two lanes of Louisiana Highway (LA) 15 across the Old River Navigation Lock and Canal in Pointe Coupee Parish. Its total length of 884 feet encompasses approach spans to the north and south and a central vertical lift span. The central steel girder span is 103 feet long and features a steel grid deck. The operating machinery, which drives the four sheaves on each corner of the lift towers, is located on a platform at the top of the central span. The movable span is flanked by six steel plate girder approach spans to the north and six steel plate girder approach spans to the south. An operator's house is located near the southeast corner of the lift span and is supported on the concrete lock structure. A fender guide system for the lock and canal provides for a 75-foot-wide navigation channel through the bridge. When the bridge is open, approximately 53 feet of vertical clearance is provided above the high water line. The bridge is classified as a complex structure because it contains one vertical lift span unit. It is also classified as fracture critical for two reasons: 1) the lift span's two-girder framing system, and 2) its floorbeams, which are spaced greater than 14 feet apart.

The bridge is in satisfactory condition overall and appears to adequately serve its purpose of carrying vehicular traffic, with the ability to open to allow water navigation traffic to pass under the bridge through the lock when it is open. The major deficiency is that the paint system on the movable portion of the bridge, including the towers, has significantly failed, and areas of exposed metal have minor surface corrosion throughout. The operation of the bridge is good, as observed in three opening-closing cycles during the field visit, and the machinery and electrical systems are adequately maintained. With proper maintenance and rehabilitation, the Old River Bridge can continue to serve in its present capacity for 20 years or longer. The bridge is maintained jointly by the U.S Army Corps of Engineers (USACE) and LADOTD per a 2014 maintenance agreement (see Appendix C). Per the agreement the USACE will perform minor and some major repair work, but more extensive rehabilitation projects will be contracted by the LADOTD with concurrence and coordination with the USACE.

Any work on the bridge should proceed according to recommendations in this Historic Bridge Management Plan (Plan), which adhere to the *Secretary of the Interior's Standards for the Treatment of Historic Properties* (Secretary's Standards), the *Management Plan for Historic Bridges Statewide* (Statewide Historic Bridge Plan), and the *Programmatic Agreement among the Federal Highway Administration, the Louisiana Department of Transportation And Development, the Advisory Council on Historic Preservation, and the Louisiana State Historic Preservation Officer Regarding Management of Historic Bridges in Louisiana* (PA).

**THIS PAGE INTENTIONALLY LEFT BLANK**

## 1. Introduction

This Plan, used in conjunction with the Statewide Historic Bridge Plan, provides guidance on the approach to preservation activities for the Old River Bridge (Recall No. 054900), identified as a Preservation Priority Bridge. Completion of individual management plans for Preservation Priority Bridges and the Statewide Historic Bridge Plan fulfills terms of the PA, which was executed on September 21, 2015.

The PA provides the basis and procedures for the management of historic bridges in Louisiana and outlines the procedures for the treatment of historic bridges, including Preservation Priority Bridges. In accordance with the PA, an owner seeking state or federal funding for Preservation Priority Bridges will be required by the Louisiana Department of Transportation and Development (LADOTD), in cooperation with the Louisiana State Historic Preservation Office (LASHPO) and the Federal Highway Administration (FHWA), to follow the procedures outlined in this Plan and the Statewide Historic Bridge Plan.

The Statewide Historic Bridge Plan outlines the overall approach to bridge preservation through a discussion of the collaboration of the historian and engineer, guidance on assessing preservation needs, and resources and technical guidance on maintenance and rehabilitation activities that are broadly applicable to historic bridges. A glossary of common engineering and historical terms is included in the Statewide Historic Bridge Plan.

This Plan for the Old River Bridge compiles and summarizes the specific historic and engineering information for this Preservation Priority Bridge. It documents the existing use and condition of the bridge, along with assessments of the preservation needs, including cost estimates. Preservation can be accomplished in two manners: preventative maintenance and rehabilitation. Maintenance includes cyclical or condition-based activities that, along with regular structural inspections, are directed toward continued structure serviceability. Rehabilitation activities are near- or long-term steps that need to be taken to preserve and in some cases restore a bridge's structural condition and serviceability. In assessing preservation activities for each Preservation Priority Bridge, a design life of 20 years was considered, which is consistent with the duration of the PA. This Plan provides the bridge owner, and other interested parties, with detailed information related to the historic nature of the bridge and the necessary background to make an informed planning decision. Recommendations within this Plan should be reviewed in 10 years following completion of the Plan to identify any needed updates or revisions.

Existing bridge data sources typically available for Louisiana bridges were gathered for this Plan, and field investigation confirmed the general structural condition and character-defining features of the subject bridge. These sources include:

- The current LADOTD Bridge Inspection Report, and any other similar inspection reports
- Original bridge construction plans, any rehabilitation plans, and record as-built plans, as available
- Existing historical and documentary material related to the historic bridges

Recommendations within this Plan are consistent with the Secretary's Standards. The Secretary's Standards are basic principles created to help preserve the distinct character of a historic property and its site, while allowing for reasonable change to meet new engineering standards and codes. The Secretary's Standards recommend repairing, rather than replacing, deteriorated features whenever possible. A version of the Secretary's Standards that is specific to historic bridges is included in the Statewide Historic Bridge Plan. Following these standards is a requirement of the PA.

A bridge historian and bridge engineer from Mead & Hunt, Inc. (Mead & Hunt) jointly prepared this Plan under contract to the LADOTD. The LADOTD, FHWA, and LASHPO reviewed and provided input into the final Plan.



## 2. Location Map

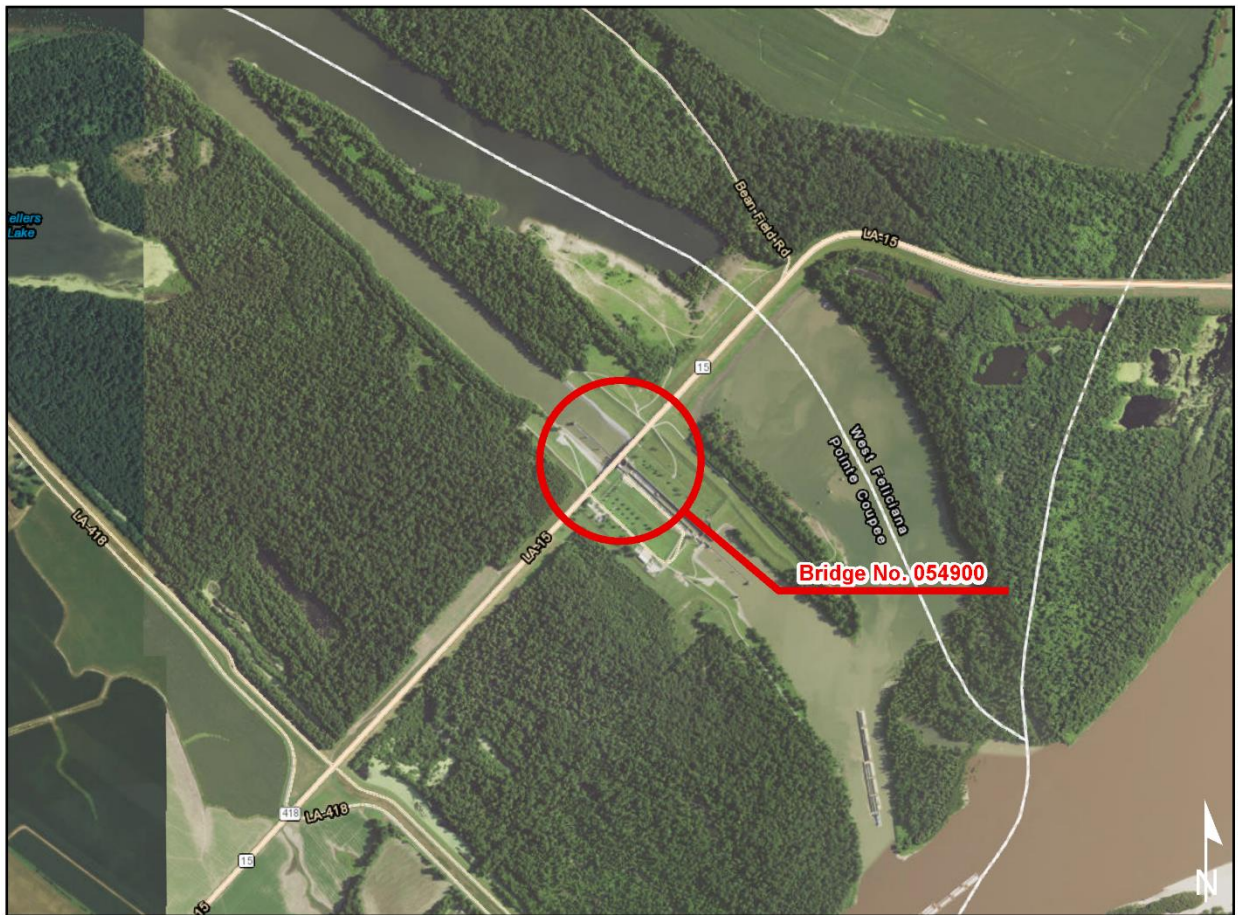

0 1,250 2,500 5,000 Feet

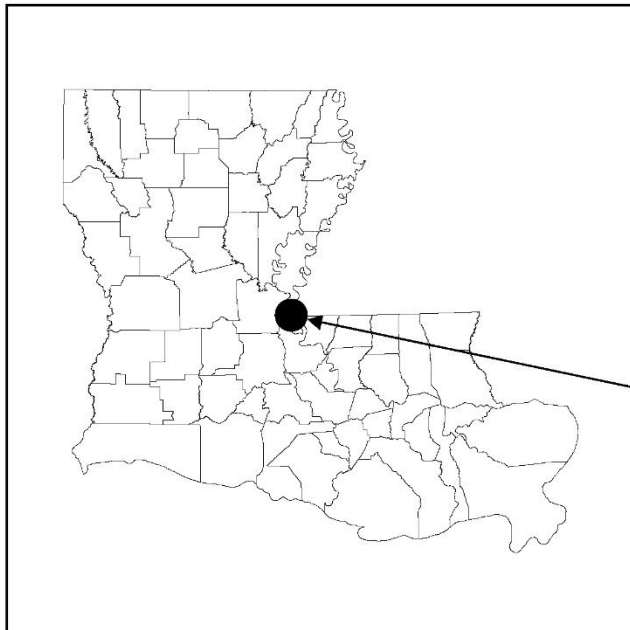

**PROJECT LOCATION**  
Bridge Number: 054900  
Stucture Number: 61391770105911  
Pointe Coupee Parish  
Route: LA 15  
Crossing Description: Old River Nav. Canal

**THIS PAGE INTENTIONALLY LEFT BLANK**

### 3. Historic Data

#### A. Identifying information

**Structure Number:** 61391770105911

**Recall Number:** 054900

**LASHPO Number:** 39-00842

**Bridge Name:** Old River Navigation Canal Bridge

**Date of Construction:** 1964-1965

**Main Span Type:** Movable: Lift – Span Tower

**Contractor:** Coastal Contractors Inc., Baton Rouge, La.

**Designer/Engineer:** Bedell and Nelson Engineers Incorporated, New Orleans, La.  
A.W. Thompson and Associates, New Orleans, La.  
W.B. Smiley Steel Company, Lake Charles, La. (steel fabrication)

#### B. Description of bridge

The Old River Bridge carries two lanes of LA 15 across the Old River Navigation Lock and Canal in Pointe Coupee Parish. The average daily traffic (ADT) across the bridge is approximately 920 vehicles. The 884-foot-long crossing consists of a central, steel, vertical lift span flanked by composite welded steel plate girder approach spans to the north and south. It provides a highway crossing over the canal and is part of the navigation lock complex. Completed in 1965, the bridge retains nearly all elements of its original construction. It is classified as a complex bridge because of the movable span. It is also classified as a fracture critical structure because of the lift span's two-girder framing system and its floorbeams, which are spaced greater than 14 feet apart. The bridge is not load (weight) posted. For purposes of descriptions in this Plan, the bridge is oriented north-south, and the navigation canal is oriented east-west.

The main span of this bridge is a 103-foot-long vertical lift span as measured from centerline to centerline of the lift tower columns. The operating machinery, which drives the sheaves (grooved steel wheels) on each of four corners of the lift towers, is located on a central platform at the top of the span. Heavy steel ropes on the sheaves are attached to the movable span below, which is counterweighted at each end. The concrete counterweights have "Old River Lock" stamped on them. The combined weight of the counterweights is equal to the weight of the lift span, and thus for movement to occur the drive machinery needs to provide only enough force to overcome friction and wind resistance with the operating machinery on top of the lift span. The lift span consists of two main longitudinal welded steel plate girders

with transverse, rolled, steel I-beam floorbeams; eight lines of rolled steel I-beam longitudinal stringers; and a 5-inch-thick open grid steel deck with checkered metal plate sidewalks on each side. The end panels of the steel grid deck are filled with concrete. The towers for the lift span are supported on top of the massive, cast-in-place, reinforced-concrete structures that form the lock portion of the navigation canal.

The southerly approach spans consist of six 65-foot-long composite welded steel plate girders for a total length of 390 feet. They feature a 7-inch-thick, cast-in-place, composite, reinforced-concrete deck with steel girders. The northerly approach spans also consist of six 65-foot-long, composite, welded, steel plate girders for a total length of 390 feet. They also feature a 7-inch-thick, cast-in-place, composite, reinforced-concrete deck with steel girders. Cast-in-place, reinforced-concrete curbs with a 1-foot, 8-inch-high single rail concrete railing are provided on each side of the deck. Expansion joints are located in the concrete deck slabs above the piers and abutments. Cast-in-place, reinforced-concrete approach slabs measuring 20 feet long are provided at each end as the roadway approaches to the bridge. The substructure for the approach spans consist of cast-in-place, reinforced-concrete abutments supported on 24-inch square precast concrete piles, and cast-in-place, reinforced-concrete pier (bent) caps supported on 24-inch square precast concrete piles that form columns for the bents. The precast concrete pile design comes from a 1957 standard plan.<sup>1</sup>

The bridge deck consists of a 28-foot clear roadway width as measured between faces of curbs for the sidewalks. There are 18-inch-wide sidewalks located on each side of the roadway, with 10.5-inch-high curbs. The sidewalks are constructed of metal plates on the lift span, and cast-in-place concrete on the approach spans. A 20-inch-high concrete barrier railing with one line of concrete rail is located on the outside of the sidewalks on the approach spans; concrete endposts on both the north and south approach span termini read “Old River Lock” and “1964.” There is no barrier railing on the lift span, because the main longitudinal girders project above the top of the sidewalk by approximately 3 feet.

Separate framed steel structures at each end of the lift span support vertical clearance signs over the roadway. They stand on cast-in-place, reinforced-concrete platforms extending from the respective bents. Vertical clearance on the signs is listed as “16 FT - 0 IN.” Traffic signals, wooden traffic gates, and steel traffic barrier gates are provided at each end of the bridge.

The operator’s house is located southeast of the lift span and is supported on the concrete lock structure. The building is two stories tall with smooth concrete facing and a flat roof with steel pipe parapet; a metal awning, added later, stretches across its north, east, and west elevations. A horizontal strip of windows is located along the north side of the house, which faces the bridge and lock. Inside, the bridge control panel and equipment is located in the upper level. An emergency generator is located in a separate facility west of the building.

---

<sup>1</sup> “Standard Plan: 24-30 and 36 Inch Precast Concrete Piles (Reinforced for Prestressed)” (Baton Rouge, La.: State of Louisiana Department of Highways, 1957).

West of the bridge a fender guide system provides a navigation channel for water traffic and is part of the larger lock and canal system. The lock structure is located under the bridge. The lock and canal system provides for 75 feet of horizontal navigation clearance under the bridge. When the span is open, there is approximately 53 feet of vertical clearance above high water elevation.

The entire original control system for this bridge was replaced in the 2000s with a computerized programmable logic control (PLC) system. This system provides for touch-screen automatic operation of the bridge, including all safety devices.

The Old River Navigation Canal is a manmade canal that is located just south of a dam and halts the flow of the Mississippi River into the Atchafalaya River via the Lower Old River. The Old River lock allows for boat travel between the Mississippi River to the east and the Atchafalaya and Red Rivers to the west. An administration building for the U.S. Army Corps of Engineers is located to the southeast of the bridge. The bridge and canal are associated with two spillways (related bridges are Recall Nos. F15771 and F15321) that are parts of the Old River Control Structure. This evaluation addresses only the highway bridge over the navigation canal and not the overall complex.

### C. History and significance

The Old River Bridge, located in northeastern Pointe Coupee Parish, carries LA 15 across the Old River Navigation Canal. Pointe Coupee Parish follows the western bank of the Mississippi River 70 miles north of Baton Rouge to the Mississippi state line. The bridge is situated between the Mississippi River to the east and the Atchafalaya River to the west, near the area where the Red River drains into the Atchafalaya. It stands approximately 2 miles southwest of the Three Rivers Wildlife Management Area, a 27,380-acre natural reserve with wetlands for sport and commercial fishing.<sup>2</sup>

The Lower Old River was created in 1831 when Henry Shreve, the founder of Shreveport, Louisiana, built a cutoff along the Mississippi River and the waterway abandoned what was previously a wide meander to follow a directed channel. The southern portion of this meander was the Lower Old River, which ran between the Mississippi River and the Atchafalaya and Red Rivers. Soon after Shreve's Cutoff changed the flow of the Mississippi, workers began to clear a 30-mile-long logjam that had long blocked the head of the Atchafalaya. Once it was gone, the Mississippi River began to flow increasingly through the Lower Old River into the Atchafalaya and threatened to change its course completely. This had the potential to destabilize the economy of the entire region, since many industries and municipalities along the Mississippi in southern Louisiana depend on its steady flow of fresh water. By the mid-twentieth century state and national leaders decided to invest in a solution.<sup>3</sup>

In the early 1950s the U.S. Army Corps of Engineers (USACE) developed a plan to dam the Lower Old River. They would also construct an outflow structure north of the Lower Old River that could better control water levels between the two rivers, particularly during flooding. The United States Congress

---

<sup>2</sup> "Three Rivers WMA," *State of Louisiana Department of Wildlife and Fisheries*, <http://184.106.97.89/wma/2754>.

<sup>3</sup> U.S. Army Corps of Engineers, "Old River Control" (New Orleans, La.: U.S. Army Corps of Engineers, 2009), 4-7.

authorized the \$67 million project in 1954 and construction began the following year. By 1963 the Old River Control project was nearly complete, including a \$15 million navigational lock just south of the Old River that allowed commercial and recreational traffic to travel between the Mississippi, Atchafalaya, and Red Rivers.<sup>4</sup> The last step would be the construction of a highway bridge that allowed vehicular traffic to cross the Old River Canal over the navigation lock.<sup>5</sup> A representative from the New Orleans division of the USACE said of the bridge that it would “put the finishing touches on what must surely be classed as one of the unique engineering feats of this century.”<sup>6</sup>

Early plans for the Old River Bridge date to 1959 and were completed as a joint venture by engineering firms Bedell and Nelson and A.W. Thompson and Associates.<sup>7</sup> The plans were approved in 1961 and the bridge received funding through the U.S. Bureau of Public Roads, the Louisiana Department of Highways, and the USACE. By 1965 the \$775,000 movable span was complete. The structure was praised for its use of innovative technology including a high-level periscope and two-camera, closed-circuit monitor used for surveillance of both vehicular and waterway traffic. Using this surveillance system for notification, the operator would open the bridge when necessary. This system remains in place today; however, the manual controls for operating the bridge were replaced with a computerized PLC system in the 2000s.<sup>8</sup>

Notably, this region was sparsely populated in the 1960s and, when the bridge was completed in 1965, the roadway north of it was not yet finished.<sup>9</sup> In addition to providing transportation over the navigation canal, the Old River Bridge eventually connected Pointe Coupee and Avoyelles Parishes with areas north along the Mississippi River via LA 15.<sup>10</sup> Today, the lock accommodates approximately 10 to 15 vessels per day, including many connected to the petrochemical, agriculture, and aggregate industries dominant throughout the region. While it has undergone major repairs, the Old River Control Complex remains in place and the Old River Bridge stands as an important part of the overall transportation system that includes the canal and its roadway crossing.<sup>11</sup>

The Old River Bridge is eligible for listing in the National Register under *Criterion A: History* as a vertical lift structure over the Old River Navigation Canal, which was constructed as part of an innovative conservation effort to ensure the Mississippi River would not divert into the Atchafalaya River while still allowing for transportation between the waterways.

---

<sup>4</sup> U.S. Army Corps of Engineers, “Old River Control,” 7-9; U.S. Army Engineer Waterways Experiment Station, “Filling and Emptying System, Old River Navigation Lock, Louisiana, Hydraulic Model Investigation” (Vicksburg, Miss.: U.S. Army Corps of Engineers, 1960), 1.

<sup>5</sup> Frederic M. Chatry, “Old River Feeds Flow of Atchafalaya,” *Times-Picayune*, January 26, 1964, section 7, 28.

<sup>6</sup> “Old River Work Nearing End,” *Times-Picayune*, January 24, 1965, section 7, 18.

<sup>7</sup> “Plans of Proposed State Highway: Old River Navigation Canal Bridge and Approaches at Old River Navigation Lock” (Baton Rouge, La.: State of Louisiana Department of Highways, 1959).

<sup>8</sup> “Highway Span is Inspected, Unit is Last of River Control Work,” *Times-Picayune*, April 1, 1965, section 3, 6; “Old River Region’s North-South Link,” *Times-Picayune*, April 2, 1965, section 1, 8.

<sup>9</sup> “Old River Region’s North-South Link.”

<sup>10</sup> “Highway Span is Inspected, Unit is Last of River Control Work.”

<sup>11</sup> U.S. Army Corps of Engineers, “Old River Control,” 9-15.

It is also eligible under *Criterion C: Engineering* as an important variation within the vertical lift bridge type. This variation is demonstrated in the centrally located drive machinery that operates the four sheaves. This variation is typically used on narrow navigation channels with spans under 200 feet. The geography and occurrence of relatively small navigable waterways in the southernmost parishes of the state may explain why this variation is relatively widely used in Louisiana, but quite uncommon nationally.<sup>12</sup>

#### **D. Character-defining features**

Character-defining features are prominent or distinctive aspects, qualities, or characteristics of a historic property that contribute significantly to its physical character. Features may include materials, engineering design, and structural and decorative details. Elements of the bridge that are not identified as character-defining features may be historic fabric. Historic fabric is material in a bridge that was part of original construction. It is important to consider both character-defining features and the bridge's historic fabric when planning any work.

The Old River Bridge has two character-defining features: its vertical lift span and the overall bridge superstructure that crosses the Old River Navigation Canal (described below). Other elements that represent historic fabric but are not considered to be character-defining are the concrete substructure; approach spans, including the endposts and railings; traffic gates; and operator's house.

The following items are the character-defining features of this bridge:

##### **Feature 1: Design and construction of a vertical lift span with central drive machinery**

This feature includes the entire main span, comprised of a vertical lift span with the operating machinery located on a platform on top of the lift span, and the machinery to drive four sheaves, one located on top of each corner of the lift towers. The lift span is comprised of two main, longitudinal, welded, steel plate girders with transverse, rolled, steel I-beam floorbeams, eight lines of rolled steel I-beam longitudinal stringers, and a grid steel deck with checkered metal plate sidewalks on each side of the roadway.

---

<sup>12</sup> Mead & Hunt, Inc., *Historic Context for Louisiana Bridges: Louisiana Statewide Historic Bridge Inventory* (prepared for the Louisiana Department of Transportation and Development, December 2013), 77.



*Character-defining Feature Photo 1: Design and construction of a vertical lift span with central drive machinery. The operating machinery, located at the center of a platform, drives the four sheaves on each corner of the lift towers.*

**Feature 2: Design and construction of a bridge over a navigation canal**

This feature includes the entire superstructure of the bridge, which crosses the Old River Navigation Canal. The canal provides passage of waterway traffic between the Mississippi River and the Atchafalaya and Red Rivers. The vertical lift configuration of the central span allows for necessary navigational clearance under the bridge.



*Character-defining Feature Photo 2: Design and construction of a bridge over a navigation canal.*





*Character-defining Feature Photo 3: Design and construction of a bridge over a navigation canal.*

The following images illustrate other bridge features that are historic fabric, meaning they are part of original construction but are not considered to be character-defining features:



*Historic Fabric Photo 1: Typical steel plate girder approach spans with concrete railing and concrete pile supports, showing traffic gates.*



*Historic Fabric Photo 2: Endposts on concrete railing of approach spans.*



*Historic Fabric Photo 3: Operator's house.*

**THIS PAGE INTENTIONALLY LEFT BLANK**

## 4. Engineering Data

### A. Existing conditions

#### (1) Structural observations

The bridge is in satisfactory condition overall and appears to adequately serve its purpose of carrying vehicular traffic over the waterway, with the ability to allow water traffic to pass under the bridge and through the lock when it is open. The major deficiency is that the paint system on the movable portion of the bridge, including the towers, has significantly failed, and areas of exposed metal have minor surface corrosion throughout. The operation of the bridge is good, as observed in three opening-closing cycles during the field visit, and the machinery and electrical systems are adequately maintained.

The bridge is classified as fracture critical for two reasons. First, the lift span is a two-girder system, with two longitudinal steel girders providing the primary structural framing and support. Second, the steel floorbeams of the lift span are greater than 14 feet apart. The latest bridge inspection report noted that fracture critical members were visually inspected, and no cracks were found.

The bridge is not load (weight) posted.

#### Approach spans

The concrete decks of the approaches spans are in satisfactory condition, with random cracking in the riding surface and on the underside, minor scaling in the riding surface, and transverse cracks noted in the underside of the deck between the girders. The deck joints (expansion joints) at each abutment have failed and are in poor condition, allowing water to pass through to the abutment below the joints and causing erosion of the embankment slopes, especially at the north abutment. Other expansion joints in the concrete decks are in satisfactory condition. The concrete sidewalks and concrete railings are in generally good condition. The welded steel plate girders are in good condition, except that the paint system has failed, causing freckled rust and surface corrosion on all the girders. The concrete substructure units (abutments and piers) are in good condition.

#### Lift span

The lift span and towers are generally in satisfactory condition, although the paint system has failed on all structural steel elements of the lift span and tower span, causing minor corrosion on all members. The open metal grid deck is in good condition with light corrosion throughout; the open metal grid deck filled with concrete is in good condition. The checkered metal plates for the sidewalks are in fair condition, mainly due to the failed paint system. The operating machinery is functional and generally in good condition. The sheaves, gears, bearings, and exposed machinery are rusty, but functioning properly. The operating electrical system is functional and

generally in good condition. The concrete structures (part of the lock system) supporting the lift towers and live load bearings of the lift span are in good condition.

The entire control system for the bridge was converted to a PLC system approximately 10 years ago. Operation of the bridge using the PLC system was observed in the operator's house.

## **(2) Non-structural observations**

Traffic gates and traffic signals are functioning properly. Heavy steel traffic barrier gates adjacent to the lift span on each side are lowered when the bridge is opened, and are in good functional and structural condition.

The operator's house is in very good condition. The control panel for operation of the bridge is a relatively new PLC system. All windows and doors are functional, and a metal stairway is used to access the upper level from the lock structure. The stairway is in good condition.

The fender system is a component of the lock and canal, and is in good condition.

The waterway banks on each end of the bridge appear to be stable and in good condition.

The concrete approach roadway slabs at each end of the bridge have been overlaid with asphalt. This asphalt is in serious condition, with spalling, rutting and many cracks.

Installations of new 16'-0" height clearance signs on each end of the structure were completed on September 15, 2016.

The roadway pavement striping across the bridge is faded.

## **(3) Serviceability observations**

The ADT across the bridge is about 920 vehicles. The bridge clear roadway width of 28 feet, 0 inches provides for two lanes of traffic, one in each direction, without shoulders. The bridge adequately handles this traffic volume.

This bridge is manned 24 hours per day with personnel in a permanent field office located near the southeast corner of the bridge. This bridge is opened approximately 15 times per day for barge traffic.

## B. Sources of information

<b>Plans available:</b>	Yes, available at the LADOTD Bridge Section office
<b>Inspection report date:</b>	August 11, 2015
<b>Fracture critical report date:</b>	(included as part of routine inspection report)
<b>Underwater inspection report:</b>	Not Applicable, because integral with lock system
<b>Date of site visit:</b>	February 4, 2016



*Condition Photo 1: General view of south side of bridge and operator's house, looking north.*



*Condition Photo 2: South approach to bridge, looking north over south approach spans.*



*Condition Photo 3: South overhead clearance sign; south approach spans.*





*Condition Photo 4: North approach top bridge, looking north.*



*Condition Photo 5: Condition of road at north approach to bridge.*



*Condition Photo 6: Underside of north approach spans, looking at Bent 10; also shows condition of failed paint system on structural steel members.*



*Condition Photo 7: Erosion under northerly most approach span at north abutment; also shows condition of failed paint system on structural steel members.*



*Condition Photo 8: North approach spans, looking east.*



*Condition Photo 9: North approach to bridge, looking south over north approach spans.*



*Condition Photo 10: Concrete deck expansion joint at north abutment.*



*Condition Photo 11: Looking southeast at lock and dam.*



*Condition Photo 12: Looking northwest at approach to lock.*



*Condition Photo 13: Operator's house as viewed from the lift span deck.*



*Condition Photo 14: Lift span deck and walkway, looking north.*



*Condition Photo 15: Underside of lift span showing steel framing and deck.*



*Condition Photo 16: Overview of approach to lock and bridge, looking southeast.*



*Condition Photo 17: South approach spans, looking southeast.*



*Condition Photo 18: Underside of south approach spans at south abutment; also shows condition of failed paint system on structural steel members.*

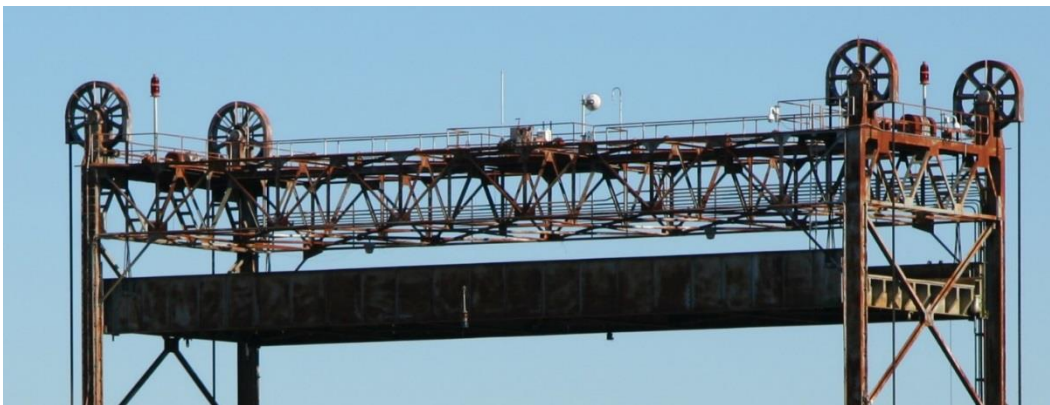

*Condition Photo 19: Top of lift span in open position, showing operating machinery.*





Photo 20: Control panel, PLC controls.

**THIS PAGE INTENTIONALLY LEFT BLANK**

## 5. Recommendations

This Preservation Priority Bridge should remain in use and can meet current and projected transportation needs for the next 20 years or more. Maintenance and rehabilitation activities should be completed in a manner consistent with the long-term preservation of this historic bridge. The Statewide Historic Bridge Plan provides additional guidance and approaches to completing maintenance and rehabilitation activities that adhere to the Secretary's Standards. Work should be conducted under the supervision of a qualified professional historian, as defined in the PA. The bridge engineer, or the bridge engineer's supervising engineer, should have demonstrated expertise in historic bridge projects and must have completed the LADOTD's historic bridge training. When developing plans and specifications for a project, the bridge engineer should follow the recommendations below.

Under the terms agreed upon in the PA, the bridge owner may undertake certain activities that are considered to be best practices without additional consultation or public notification. These activities are documented in Attachment 5 of the PA and are limited to the activities specifically noted. All recommended preventative maintenance and rehabilitation activities for this bridge are included in Attachment 5 and are not expected to alter character-defining features or historic fabric of the bridge. Some cyclical or condition-based maintenance items are noted below under Rehabilitation because they are expected to be completed as part of an overall rehabilitation project for this bridge. These activities may need to be completed as conditions dictate to promote long-term preservation of this historic bridge. Recommendations within this Plan should be reviewed in 10 years following completion of the Plan to identify any needed updates or revisions.

The opinions of probable costs provided below are in 2016 dollars. The costs were developed without benefit of preliminary rehabilitation plans and are based on the above identified tasks using engineering judgment and/or gross estimates of quantities and historic unit prices and are intended to provide a programming level of estimated costs. Refinement of the probable costs is recommended once preliminary plans have been developed. The estimated preservation costs include a 10% contingency and 7% mobilization allowance of the preservation activities, excluding soft costs. Actual costs may vary significantly from those opinions of cost provided herein. Engineering design, historical consultation, and construction administration costs are not included as these may be provided by the owner or consultants.

The bridge is maintained jointly by the USACE and LADOTD per a 2014 maintenance agreement (see Appendix C). Per the agreement the USACE will perform minor and some major repair work, but more extensive rehabilitation projects will be contracted by the LADOTD with concurrence and coordination with the USACE.

**A. Preventative maintenance**

The following recommendation is for cyclical maintenance. There are no condition-based maintenance recommendations at this time, based on the bridge condition as observed during the site visit and as documented in available information.

1. Lubricate operating machinery for the bridge regularly to maintain good condition. Because this activity is routinely done, the cost is not included in the cost estimate.

**B. Rehabilitation**

The following are recommendations for rehabilitation. These activities should be performed when necessary (estimated to be within the next five years):

1. Clean and paint the entire lift span structural steel framing system, including the structural steel framing system for both towers, in accordance with the current standard cleaning and painting specification.
2. Clean and paint the sidewalks of the lift span in accordance with the current standard cleaning and painting specification.
3. Clean and paint the exposed operating machinery, including sheaves, shafts, speed reducers, bearings, and motors.
4. Clean and paint the structural steel members in the approach spans in accordance with the current standard cleaning and painting specification.
5. Remove and replace expansion joints in the concrete roadway decks at each abutment.
6. Regrade and provide riprap stone protection on embankment at north abutment.
7. Remove and replace asphalt overlay on approach roadway pavement at each end of the bridge.
8. Restripe pavement markings across the bridge and approach roadway using a double yellow centerline and single white edge lines.

Bridge Recall No. 054900			Date:	3/28/2017	
Old River Navigation Canal Bridge					
Opinion of Probable Costs					
Rehabilitation					
Item	Quantity	Unit	Unit Cost	Total	
Clean and paint entire lift span structural steel, incl. structural steel framing system for both towers, in accordance with the current standard cleaning and painting specification	1	LS	\$1,300,000	\$1,300,000	
Clean and paint the sidewalks of the lift span in accordance with the current standard cleaning and painting specification	1	LS	\$15,000	\$15,000	
Clean and paint the exposed operating machinery, including sheaves, shafts, speed reducers, bearings and motors	1	LS	\$100,000	\$100,000	
Clean and paint the structural steel members in the approach spans in accordance with the current standard cleaning and painting specification	1	LS	\$200,000	\$200,000	
Remove and replace expansion joints in concrete roadway decks at each abutment	66	LF	\$75	\$4,950	
Regrade and provide riprap stone protection on embankment at north abutment	1	LS	\$10,000	\$10,000	
Remove and replace asphalt overlay on approach roadway pavement at each end of bridge	120	SY	\$150	\$18,000	
Restripe pavement markings across the bridge and approach roadway using a double yellow centerline and single white edge lines	4,000	LF	\$2	\$6,000	
Temporary signs and barricades; temporary traffic control for detour	1	LS	\$75,000	\$75,000	
Item Subtotal				\$1,728,950	
Contingency			10.00%	\$172,895	
Mobilization			7.00%	\$133,129	
<b>TOTAL ESTIMATED CONSTRUCTION COST</b>				<b>\$2,034,974</b>	
			Round to:	<b>\$2,035,000</b>	

**C. Identification of any anticipated design exceptions**

No design exceptions were noted, nor are any design exceptions recommended.

**THIS PAGE INTENTIONALLY LEFT BLANK**

**Appendix A. Historic Inventory Form**

**THIS PAGE INTENTIONALLY LEFT BLANK**



# Louisiana Historic Bridge Inventory

Recall Number: 054900

Structure Number: 61391770105911

SHPO Number: 39-00842

Bridge Name: OLD RIVER NAVIGATION CAN

## Location Data:

District: 61

Parish: Pointe Coupee

Feature Crossed: OLD RIVER NAV. CANAL

Facility Carried: LA0015

Location: LA0015

City, Village or Town (if applicable):

Status: Open

Bridge Owner: State of Louisiana

Latitude: 31.001639

Longitude: -91.675278

---

## Structural Data:

Bridge Type: Steel Vertical Lift Span

Year Built: 1961

Main Span Configuration (if applicable): Tower drive with connected towers

Maximum Span Length (feet): 102

Number of Spans: 1

Overall Structure Length (feet): 882

Approach Span Type (if applicable): Steel stringer/multi-beam or girder

Posted Load:

Current ADT: 000540

---

## Design and Construction Data:

Engineer or Builder:

Unknown

Bridge Plaque:

None

---

## National Register of Historic Places Evaluation:

This tower drive with connected towers vertical lift bridge has significance for its association with important trends or events that have made a significant contribution to the broad patterns of Louisiana history. Its significance is demonstrated in the area of Conservation and Transportation as a vertical lift structure over the Old River Navigation Canal. The bridge and canal were constructed as part of a larger conservation effort to ensure in the late 1950s the Mississippi River would not divert into the Atchafalaya River. The canal was constructed to provide passage of waterway traffic between the Mississippi River and the Atchafalaya River, while the bridge carries LA 15 over the canal. The vertical lift configuration allowed for necessary navigational clearance under the bridge. The bridge and canal are associated with two spillways (related bridges are Recall Nos. F15771 and F15321) that make up the larger Old River Control Structure.

The bridge also possesses significance as a movable bridge and as an important variation within the vertical lift bridge type. This variation is demonstrated in the location of the drive machinery at the center of a fixed span that operates the four sheaves. This configuration is uncommon nationally and represents a variation based on the small size of the navigation channel and necessary span length. The bridge retains good integrity and clearly conveys design features that demonstrate its significance as an integral component of a larger conservation project and as a variation within the vertical lift bridge type. This bridge is eligible for the National Register under Criterion A: Conservation and Transportation and Criterion C: Design/Engineering.

---

Within/Adjacent to Known Historic District: N/A

National Register Historic District Name: N/A

National Register Determination: Eligible

National Register Determination Date: 2013

Surveyor: Mead & Hunt, Inc.

Date Surveyed: 2013



# Louisiana Historic Bridge Inventory

Recall Number: 054900

Structure Number: 61391770105911

Bridge Name: OLD RIVER NAVIGATION CAN

Parish: Pointe Coupee

Bridge Owner: State of Louisiana

Feature Crossed: OLD RIVER NAV. CANAL

Facility Carried: LA0015

## Photographs:



**Appendix B. Select Plan Sheets**

**THIS PAGE INTENTIONALLY LEFT BLANK**

5	STATE PROJECT	ROAD	SHEET NO.
100 04	177-01-05	ROUTE 1004	5

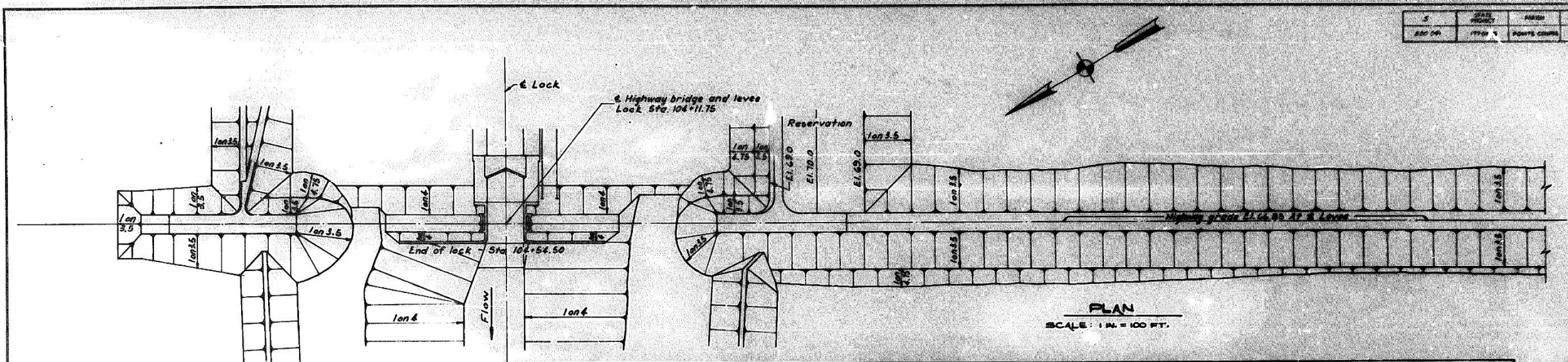

PLAN  
SCALE: 1 IN. = 100 FT.

**NOTE "A"**  
 Highway grade and vertical alignment at bridge approach is based on gross grade of existing levee at elevations shown.  
 General Contractor will be provided with proper highway grade and vertical alignment after levee settlement has occurred and prior to commencement of work on highway.

Sta. 83+57+22.00  
Begin State Project No. 177-01-05  
Contract No. 1

Sta. 83+60+00

Highway bridge & lock - Sta. 83+65+10.00

ITEM	SUMMARY OF QUANTITIES																																
	1	2	3	4	5	6	7	8	9	10	11	12	13	14	15	16	17	18	19	20	21	22	23	24	25	26	27	28	29	30			
APPROACHES	3154	8978	8404	665	98.5	1761	4552	150	72	173	1823	2155	11.80	2500	1000	2000	370	484	4	5	1000	1000	51	120.4	100	100	4	1000	1000	23.5	2.8	2.8	1000
BRIDGES																																	
TOTAL	3154	8978	8404	665	98.5	1761	4552	150	72	173	1823	2155	11.80	2500	1000	2000	370	484	4	5	1000	1000	51	120.4	100	100	4	1000	1000	23.5	2.8	2.8	1000

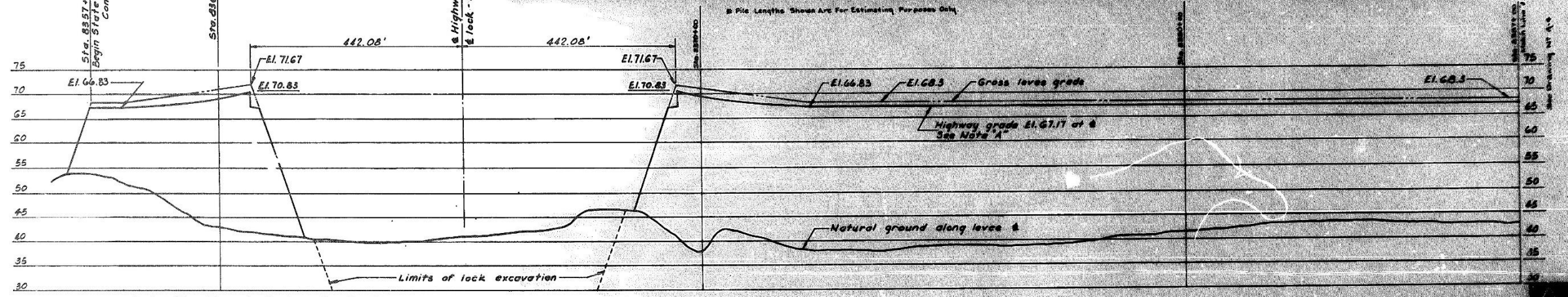

Note: Elevations in feet - refer to M.S.L.

PROFILE  
 SCALE: HORIZONTAL: 1 IN. = 100 FT.  
 VERTICAL: 1 IN. = 10 FT.

FINAL TRACINGS

STATE OF LOUISIANA  
 DEPARTMENT OF HIGHWAYS  
 BRIDGE OVER  
 OLD RIVER NAVIGATION CANAL  
 HIGHWAY  
 PLAN AND PROFILE

DATE	BY	IN CHARGE
11/22/57	J. W. THOMPSON AND ASSOCIATES	

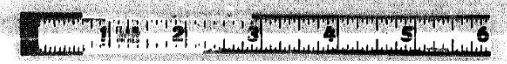

93

S	STATE PROJECT	PARRISH	SHEET NO.
280 (6)	1774-85	PORTS CANAL	4

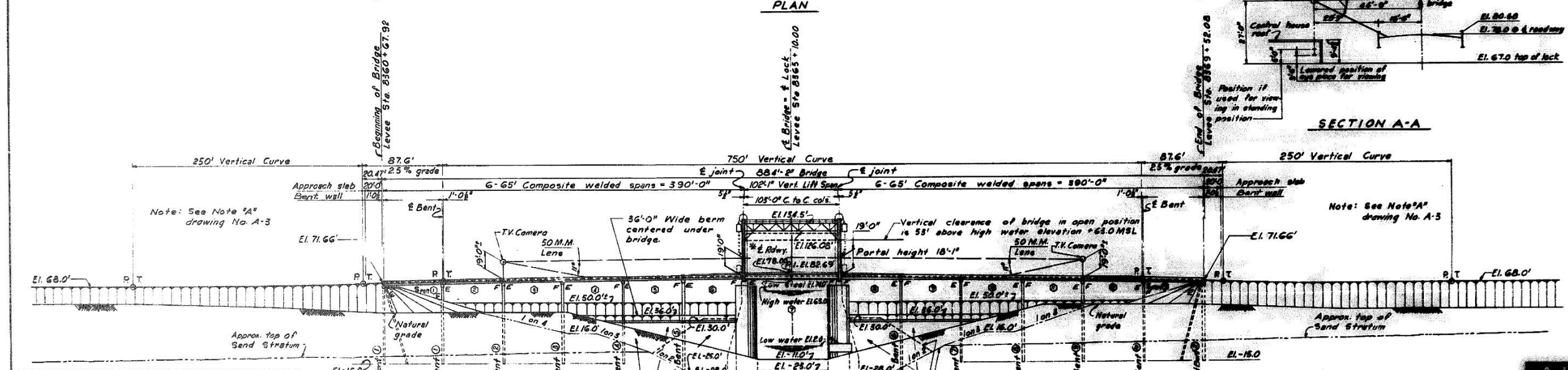
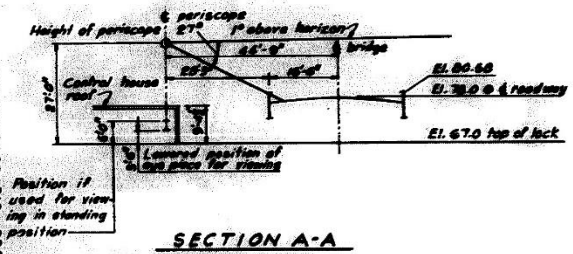
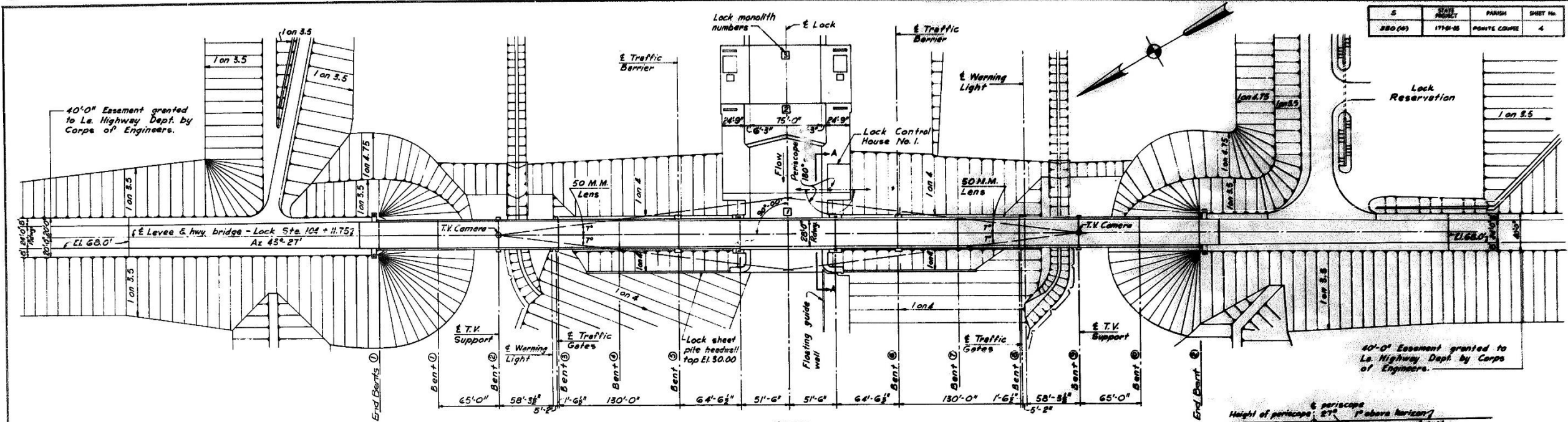

VERTICAL CONTROL DATA

	ELEVATION AT E	ELEVATION AT T	PILE CUT-OFF AT TYPICAL BARRIERS	PILE CUT-OFF AT TRAFFIC PLATFORM
End of bridge	71.66	68.08	66.17	-
Bent 1	73.29	67.71	67.80	-
Bent 2	74.78	71.20	69.29	-
Bent 3	75.98	72.40	70.49	-
Bent 4	76.91	73.33	71.42	-
Bent 5	77.55	73.97	72.06	70.80
Lock-well	77.91	-	-	-
E of bridge	78.00	-	-	-

Notes:

All Elevations are in feet M.S.L.

Tip of all piles except at Bents 5 & 6 shall be at El. -15.0'

Tip of piles at Bents 5 & 6 shall be at El. -25.0'

Vertical curve camber for 65' spans in 750' curve equals  $\frac{1}{8}"$  at  $\frac{1}{4}$  points and  $\frac{1}{4}"$  at center

\* SEE DRAWING L-4

NOTE: Name of waterway and Date of Construction required each end of bridge. See STD. Plans C.M. 55 and C.M. 97.

STATE OF LOUISIANA  
DEPARTMENT OF HIGHWAYS

BRIDGE OVER  
OLD RIVER NAVIGATION CANAL

GENERAL PLAN  
AND ELEVATION

DATE: JULY 1952

DESIGNED BY: JOSEPH VENTURE

IN CHARGE OF: [Signature]

H-4-22597



FINAL TRACINGS

95

S	STATE PROJECT	FIELD	SHEET No.
280 240	170-05	PONTE COUPE	7

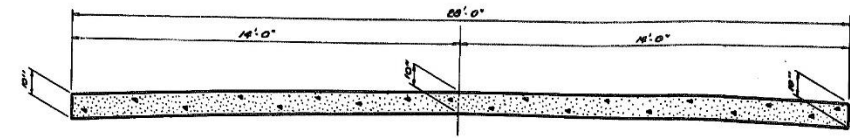

SECTION B-B  
Reinforcing Steel Not Shown

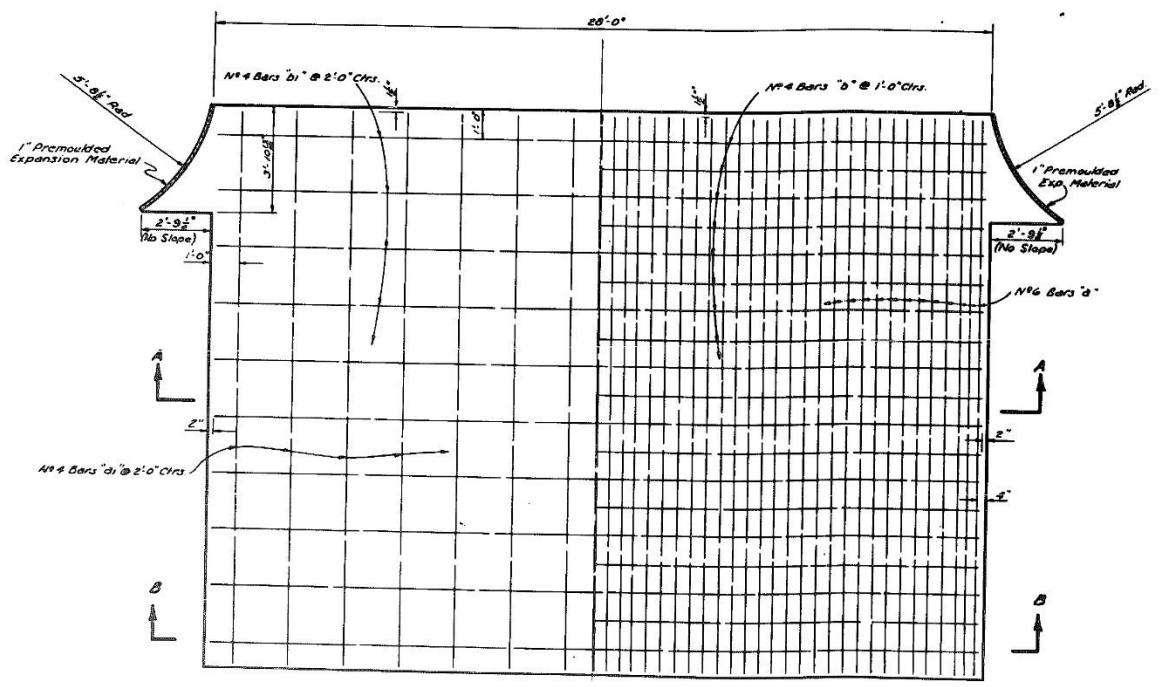

HALF PLAN  
SHOWING REINFORCING STEEL IN TOP OF SLAB

HALF PLAN  
SHOWING REINFORCING STEEL IN BOTTOM OF SLAB

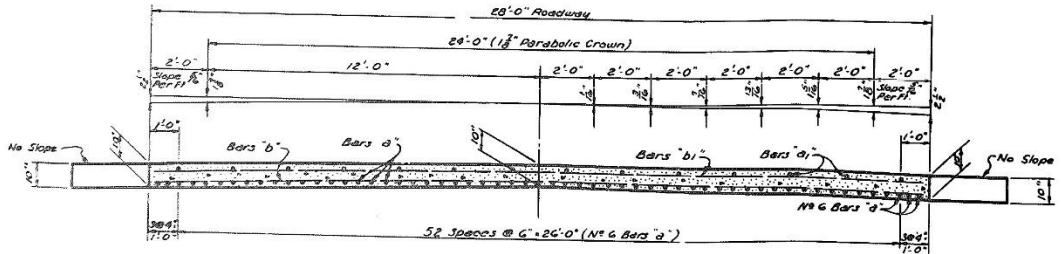

SECTION A-A

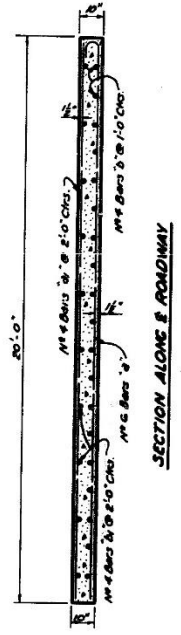

SECTION ALONG E ROADWAY

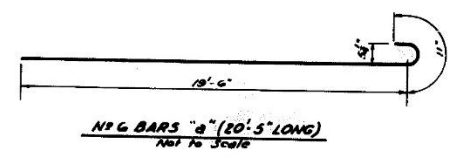

NOTE:  
1\"/>

BILL OF MATERIAL (ONE SLAB)				
BAR SIZE	NO.	UNIT LETH.	TOTAL LETH.	LOCATION
a	NO. 4	27	20'-0"	Bottom of Slab
TOTAL NO. 4 BARS = 1165'-0"			1760 POUNDS	
d	NO. 6	16	18'-0"	Top of Slab
b	NO. 6	10	27'-0"	Bottom of Slab
e	NO. 6	10	27'-0"	Top of Slab
TOTAL NO. 6 BARS = 1075'-0"			781 POUNDS	
TOTAL REINFORCING STEEL			2460 POUNDS	
CONC. APPROACH SLAB			63.08 CU. YDS.	

GENERAL NOTES

- CONSTRUCTION SPECIFICATIONS: Latest approved Le Dept. of Hwys. Std. Specs.
- DESIGN SPECIFICATIONS: A.A.S.H.O. Std. Specs. for Highway Bridges, 1957
- Third Printing, as amended to Dec. 31, 1958.
- Live Load: H20-S16-44 (Modified)
- Reinforcement bars shall be intermediate or Hard Grade, A.S.T.M. A15 or Rail Steel, A.S.T.M. A16 conforming to A.S.T.M. A305.
- All dimensions to reinforcing steel are to bar centers.
- All exposed corners to be chamfered 1/4" unless otherwise noted.
- End Bent is designed to provide for future extension of Bridge.
- Welding shall conform to Specs. for Welded Highway and Railway Bridges, 1956, of the American Welding Society and Le Dept. of Hwys. Special Provisions.
- Surface finishes, where indicated, shall conform to the American Standards for surface roughness, waviness and lay part I, A.S.A. B461-1947.
- Shop connections 3/4" rivets, open holes 1/4" unless otherwise noted.
- (a) Field connections 3/4" rivets, unless otherwise noted.
- (b) All rivets shall conform to A.S.T.M. A111.
- (c) The contractor may substitute Hi-Strength bolts for rivets for all field conn.
- Material Marked (L.A.) shall be Manganese Manganese Steel (A.S.A. B461).
- (a) The bronze self-lubricated bearing plates shall conform to A.S.T.M. B22-52 Alloy B.
- (b) Contact surfaces shall be finished in the direction of motion to A.S.A. B461-47 N°125.
- R - Denotes Clean & Rubbed Finish.

FINAL TRACINGS

A6

STATE OF LOUISIANA  
DEPARTMENT OF HIGHWAYS

BRIDGE OVER  
OLD RIVER NAVIGATION CANAL

20'-0" REINF. CONC. APPROACH SLAB

DATE: JULY 14 1959

REBEL & NELSON ENGINEERS INCORPORATED      A. W. THOMPSON AND ASSOCIATES

JOINT VENTURE

NO.	DESCRIPTION	BY	DATE









98

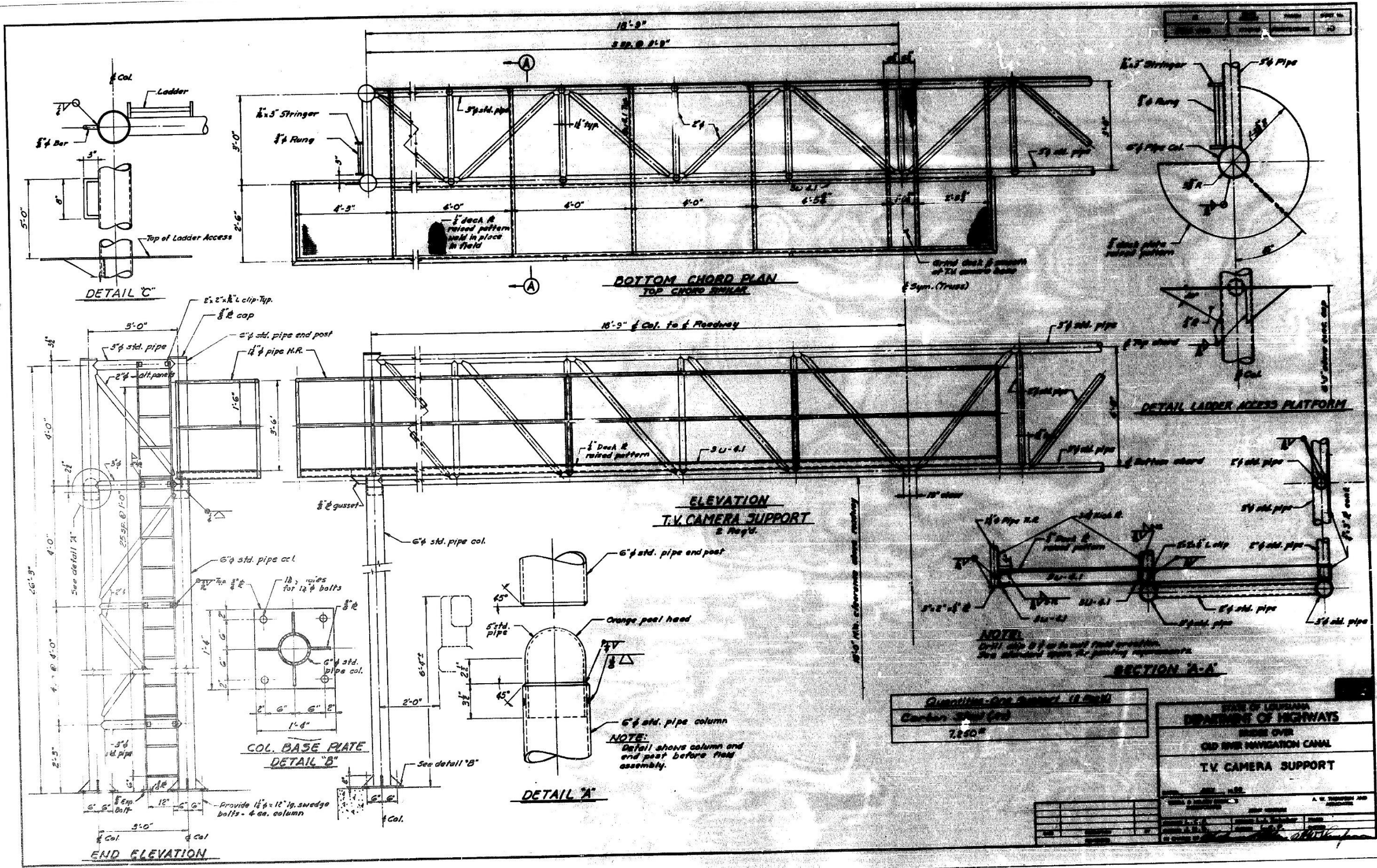

FINAL TRACINGS



Quantity - One Support (1.000)
Carbon Steel Pipe
2250'

STATE OF LOUISIANA	
DEPARTMENT OF HIGHWAYS	
BRIDGE OVER	
OLD RIVER NAVIGATION CANAL	
T.V. CAMERA SUPPORT	
DATE	11-82
DESIGNED BY	A. W. THOMPSON AND ASSOCIATES
CHECKED BY	
APPROVED BY	

101

5	STATE PROJECT	PARISH	SHEET NO.
880 (4)	1794-45	POINTE CAULLE	15

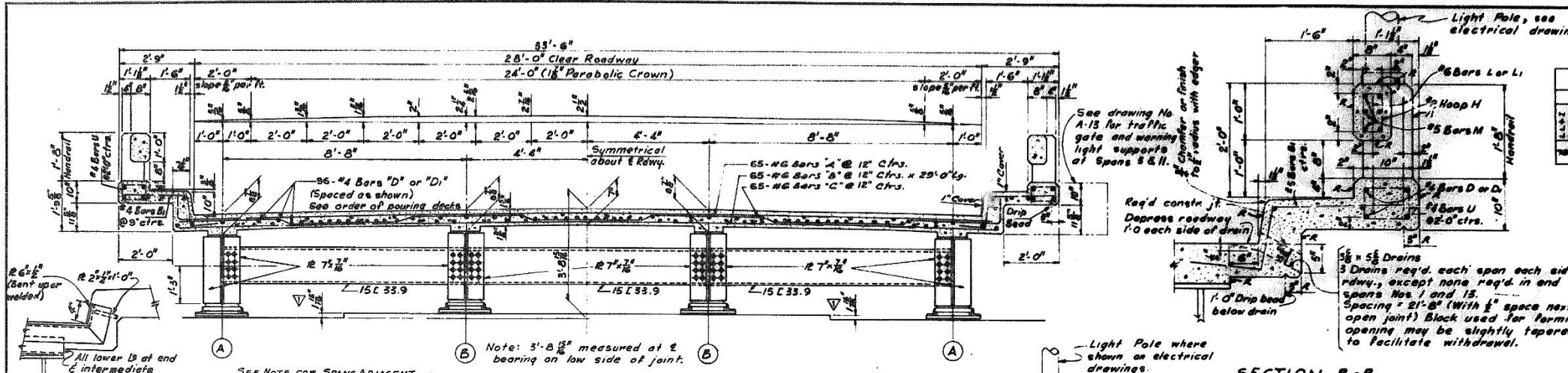

MOMENTS AND REACTIONS											
BEAM A						BEAM B					
Span	Reaction	Moment	Reaction	Moment	Reaction	Span	Reaction	Moment	Reaction	Moment	Reaction
100.0	964.1	211.5	1558.9	36.1	874.8	488.3	1558.1	30.4			

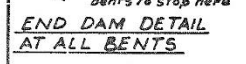

TYPICAL SECTION THRU ROADWAY AT BENT 65'-0" SPAN

SECTION B-B Showing drain detail

Equal Spacing - Span Length

CAMBER IN BEAMS FOR DEAD LOAD DEFLECTION

Beam	A	B
Span	10'	10'
Reaction	12'	12'
Moment	2'	2'
Reaction	12'	12'
Moment	2'	2'

Comber for vertical curvature of grade, to be added to D.L. camber shown above = 3/8" at Point 'a' - 3/8" at Point 'b'

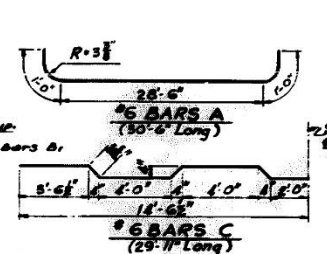
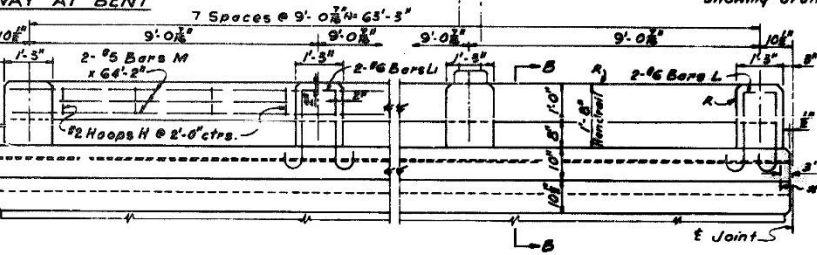
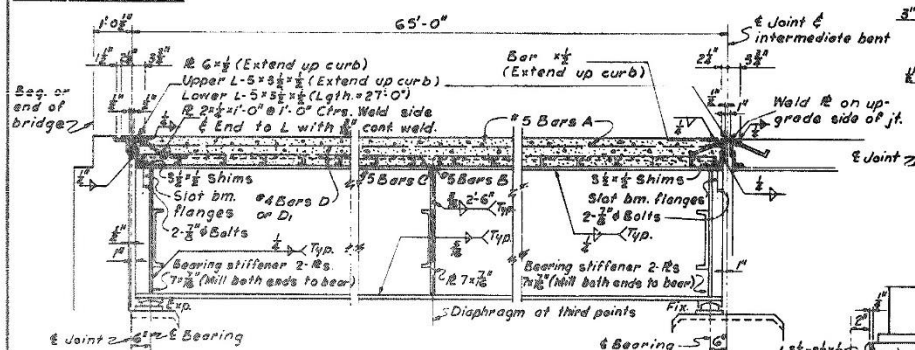

ORDER OF POURING DECKS

Note: Contractor may pour each span in one continuous pour of his election.

BILL OF MATERIAL (ONE SPAN)				
Item	Size	Unit	Total Length	Location
A	#4	60	27'-0"	Transv. in top of slab
B	#6	60	27'-0"	Transv. in bottom of slab
C	#6	60	27'-0"	Transv. in slab
D	#4	60	27'-0"	Transv. in sidewalk
E	#4	60	27'-0"	Longitud. top of slab
F	#4	60	27'-0"	Stirrups in sidewalk
G	#4	60	27'-0"	Stirrups in sidewalk
H	#2	60	27'-0"	Stirrups in sidewalk
I	#2	60	27'-0"	Stirrups in sidewalk
J	#2	60	27'-0"	Stirrups in sidewalk
K	#2	60	27'-0"	Stirrups in sidewalk
L	#2	60	27'-0"	Stirrups in sidewalk
M	#2	60	27'-0"	Stirrups in sidewalk
N	#2	60	27'-0"	Stirrups in sidewalk
O	#2	60	27'-0"	Stirrups in sidewalk
P	#2	60	27'-0"	Stirrups in sidewalk
Q	#2	60	27'-0"	Stirrups in sidewalk
R	#2	60	27'-0"	Stirrups in sidewalk
S	#2	60	27'-0"	Stirrups in sidewalk
T	#2	60	27'-0"	Stirrups in sidewalk
U	#2	60	27'-0"	Stirrups in sidewalk
V	#2	60	27'-0"	Stirrups in sidewalk
W	#2	60	27'-0"	Stirrups in sidewalk
X	#2	60	27'-0"	Stirrups in sidewalk
Y	#2	60	27'-0"	Stirrups in sidewalk
Z	#2	60	27'-0"	Stirrups in sidewalk

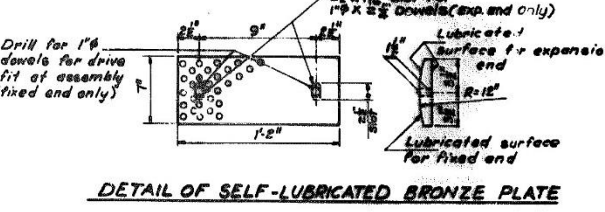
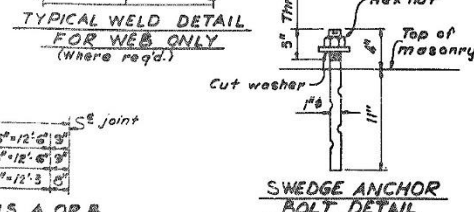
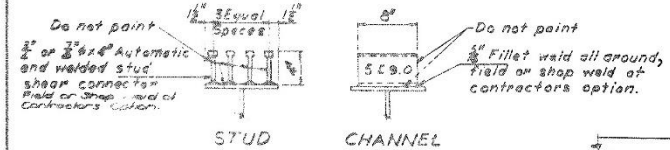
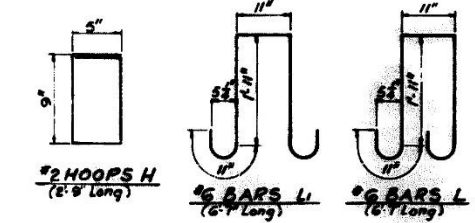
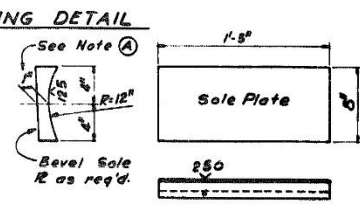
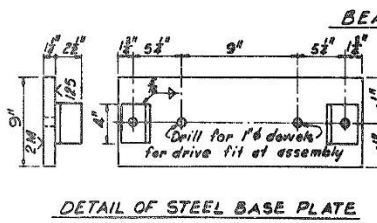
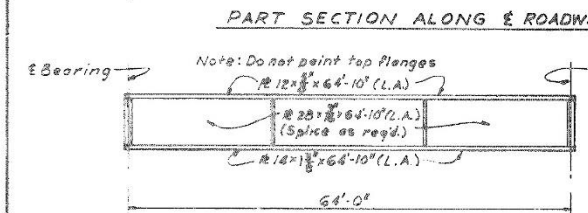

SPACING OF SHEAR CONNECTORS BEAMS A OR B

Span	5'	10'	15'	20'	25'	30'	35'	40'	45'	50'	55'	60'
Stud	12"	12"	12"	12"	12"	12"	12"	12"	12"	12"	12"	12"
Channel	12"	12"	12"	12"	12"	12"	12"	12"	12"	12"	12"	12"

\*NOTE:

SPANS G & B TO HAVE FULL CROWNED SECTION OVER BENTS 5 & 6 AND ROAD SURFACE SHALL BE WARPED TO NO CROWN AT JUNCTION WITH LIFT SPAN ELEVATION OF GUTTER SHALL BE 5" BELOW VERTICAL CURVE AS SHOWN ON DRAWING AL. CONCRETE THICKNESS OF 8" ABOVE ALL STRAINERS SHALL REMAIN CONSTANT AND BOTH DEAD LOAD AND VERTICAL CURVE CAMBER SHALL BE AS SHOWN IN TABLE.

STATE OF LOUISIANA  
DEPARTMENT OF HIGHWAYS

BRIDGE OVER  
OLD RIVER NAVIGATION CANAL

65 FT. COMPOSITE WELDED SPAN

DATE: JULY 1950

DESIGNED BY: J. A. ...

CHECKED BY: ...

IN CHARGE OF: ...

FINAL TRACINGS



123

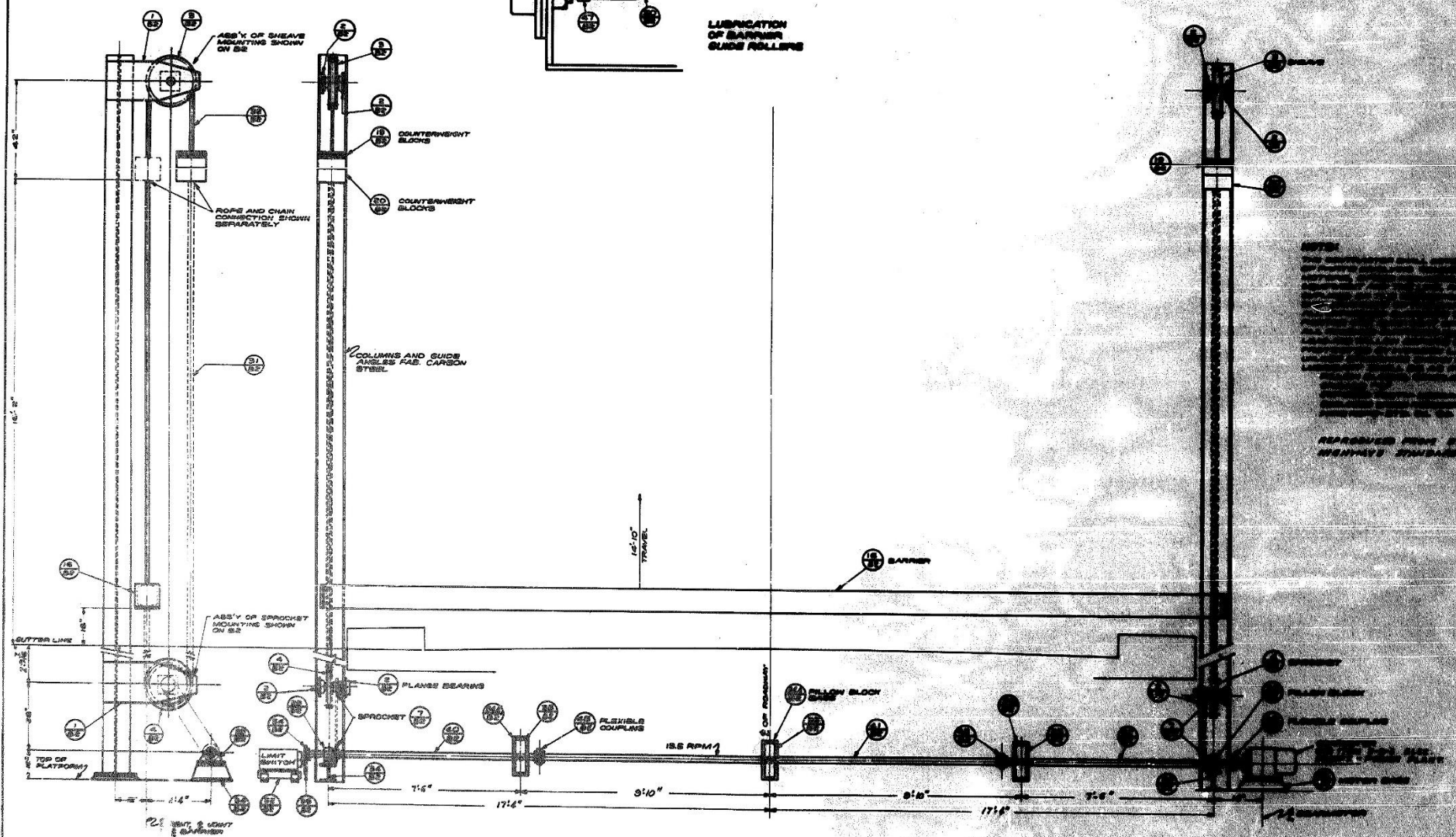
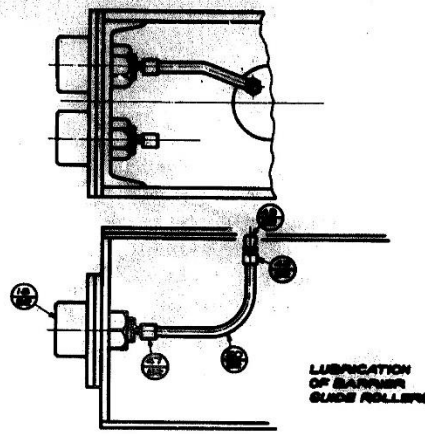
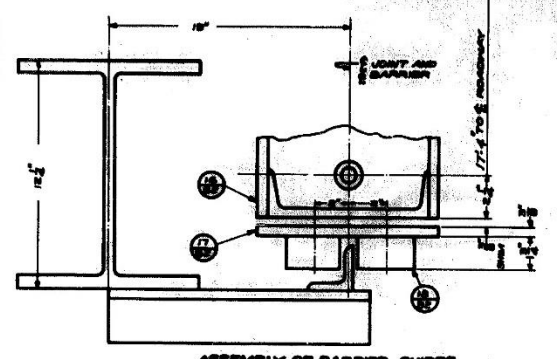

REPRODUCED FROM STATE OF LOUISIANA DEPARTMENT OF HIGHWAY TRANSPORTATION

NO.	DATE	BY	CHKD.
1	1/15/58	J. W. BROWN	J. W. BROWN
2			
3			

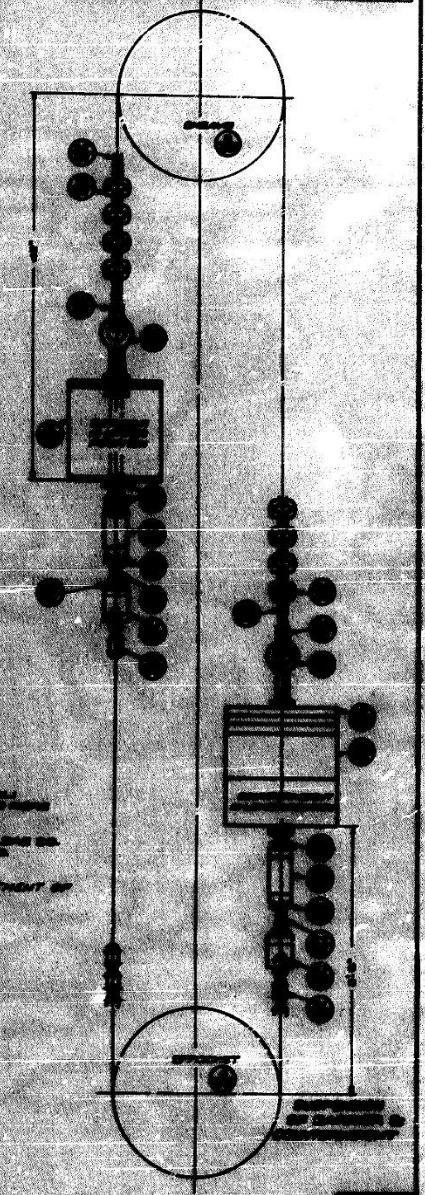

FINAL TRACINGS

STATE OF LOUISIANA  
DEPARTMENT OF HIGHWAYS  
BRIDGE OVER  
OLD RIVE NAVIGATION CANAL  
TRAFFIC BARRIER  
GENERAL ASSEMBLY





105

S	SCALE PROJECT	PARCH	SHEET NO.
350 (4)	1991-05	POINTE COUPEE	20

Quantities ~ Lift Span					
R.F. FLOOR	GRID FLOOR	Class 'A' Concrete	Manganese Vanadium SH(A440) lbs	CARBON STEEL (A7) lbs	CARBON STEEL (A36) lbs
Sq. ft	Open grid Sq. ft.	lb/s	Cu. yds.		
500	2839	2250	17.2	48,040	29,630

\*Includes 5,625 lbs. R.P. Floor R.

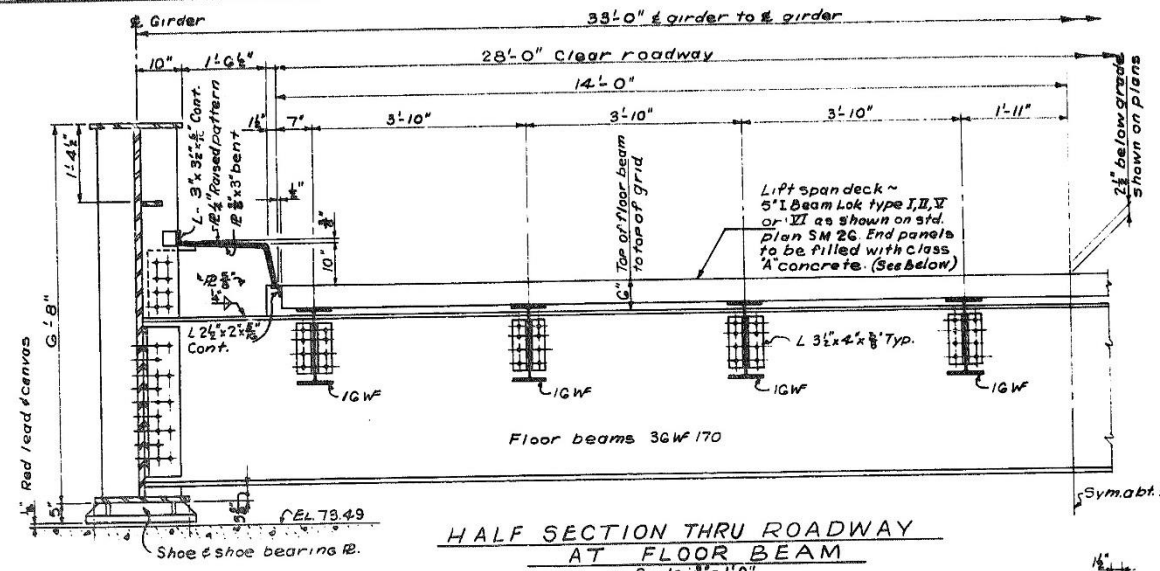

HALF SECTION THRU ROADWAY AT FLOOR BEAM  
Scale: 1/2" = 1'-0"

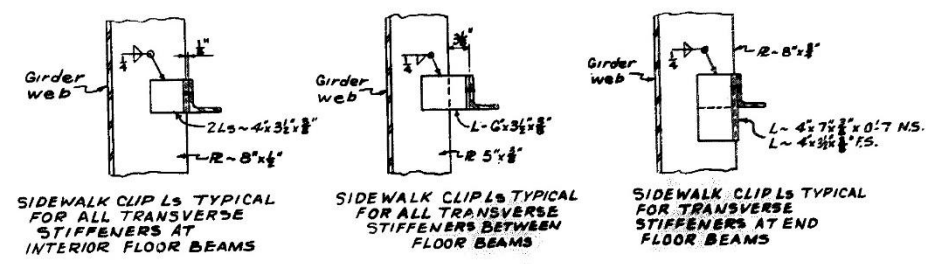

SIDEWALK CLIP L DETAILS  
NO SCALE

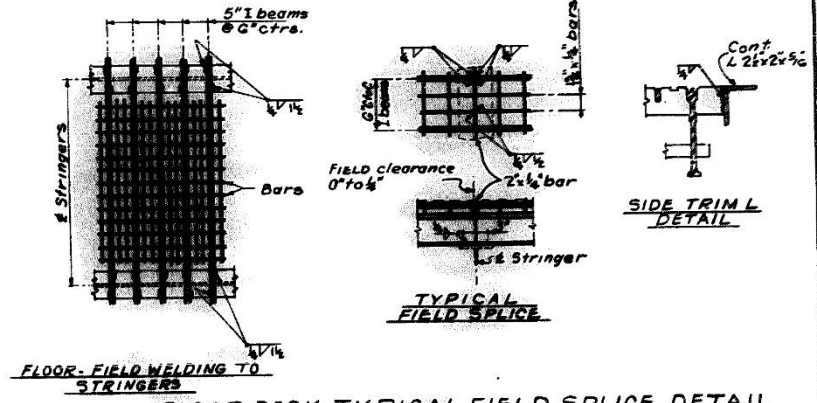
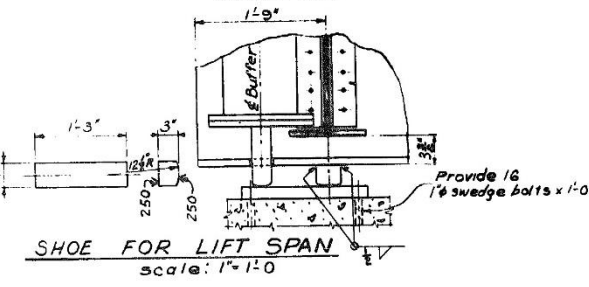
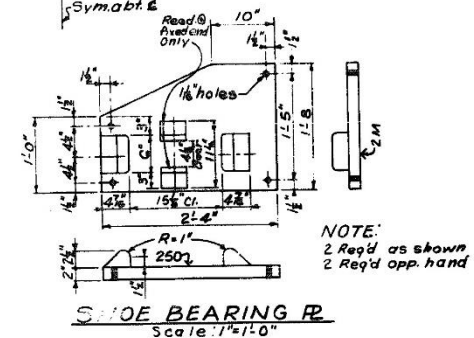
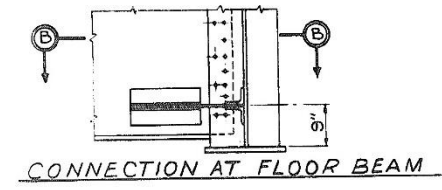
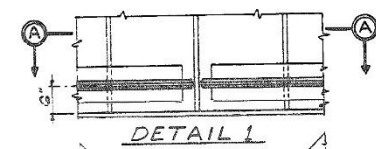

FLOOR DECK TYPICAL FIELD SPLICE DETAIL  
No Scale

NOTES:  
For general notes, see drawing No. AG.  
All structural connections, rivets or high tensile bolts unless otherwise noted.  
Main girders to be ASTM A 441 steel.  
Stringers to be ASTM A 36 steel.  
All other steel to be ASTM A 7 steel.

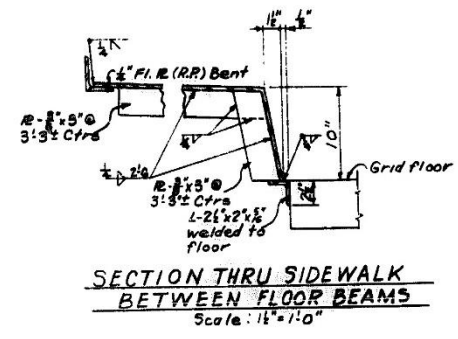
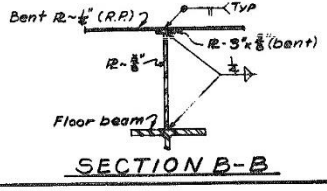
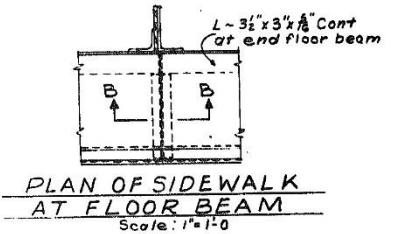
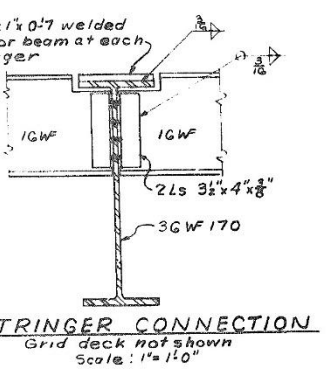
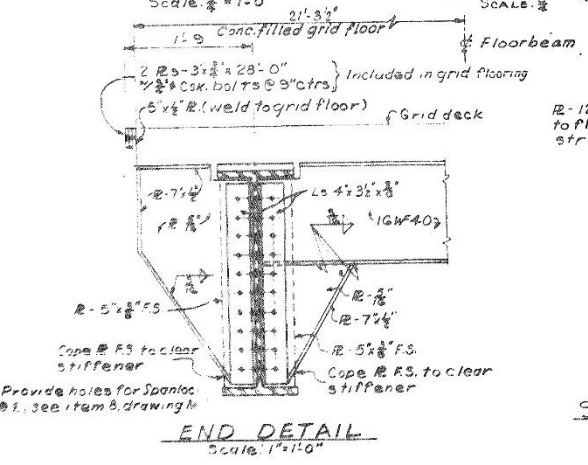

STATE OF LOUISIANA  
DEPARTMENT OF HIGHWAYS  
BRIDGE OVER  
OLD RIVER NAVIGATION CANAL  
LIFT SPAN DETAILS

DATED: JULY 1958

REVELL & NELSON ENGINEERS INCORPORATED  
JOINT VENTURE  
A. W. THOMPSON AND ASSOCIATES

DESIGNED	H.L.L.	DRAWN	E.A.C.	CHECKED	W.E.T.
DATE		DESCRIPTION		BY	
		REVISIONS			

IN CHARGE OF: *[Signature]*  
H-4-22597

FINAL TRACINGS



109

S	DATE	REVISION	SHEET
880 (A)	TTT-01-66	PORTS - UPPL	20A

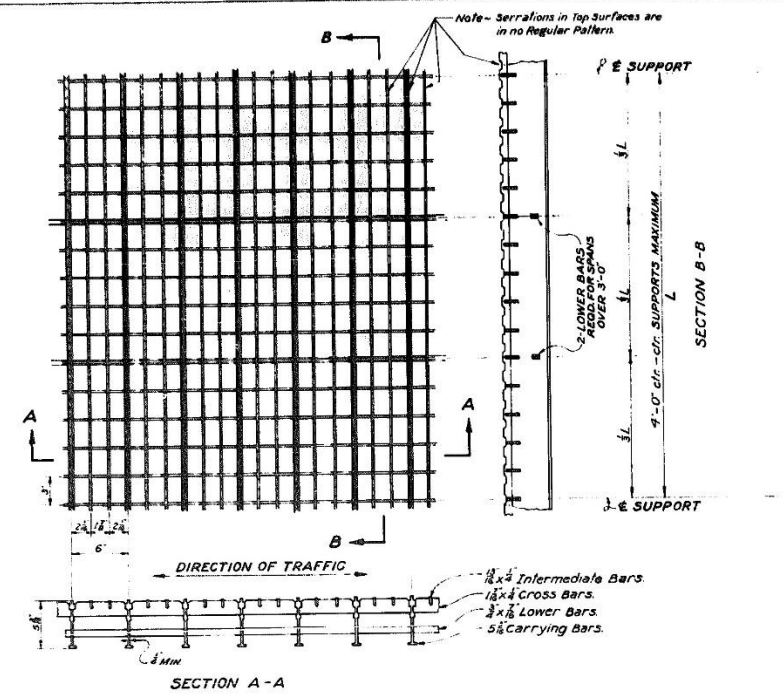

**BRIDGE FLOORING TYPE I**  
(U.S. STEEL I-BEAM LOCK)

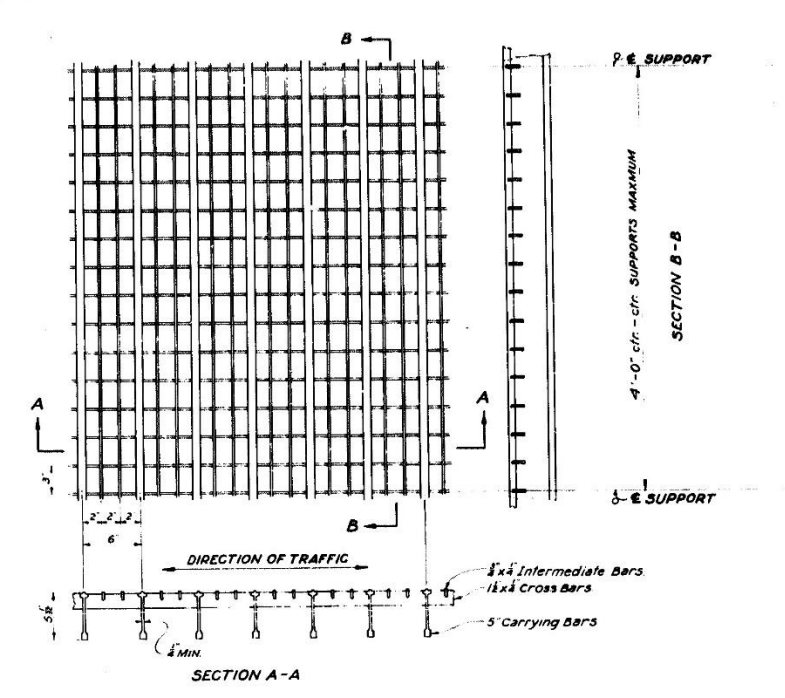

**BRIDGE FLOORING TYPE II**  
(RELIANCE STEEL PRODUCTS CO.)

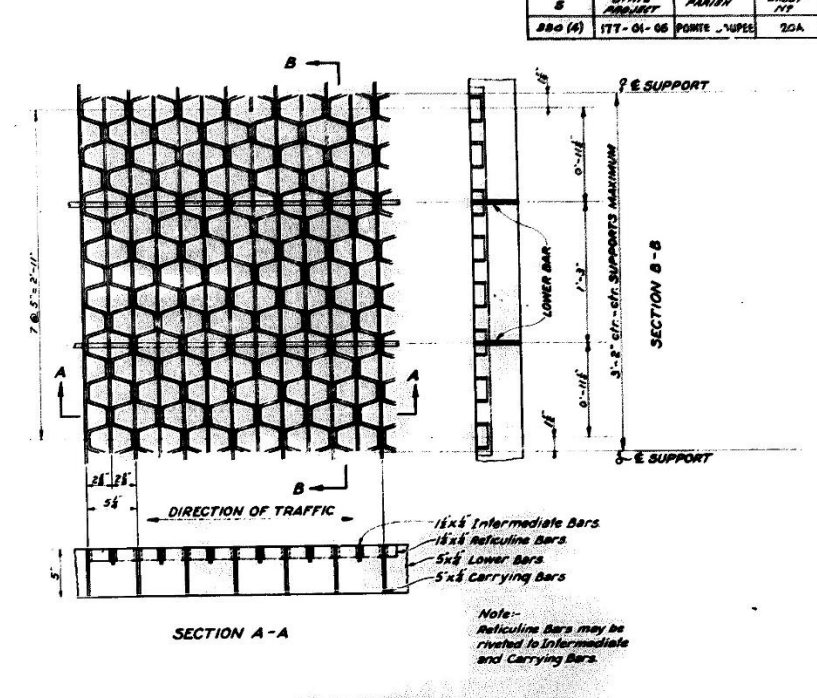

**BRIDGE FLOORING TYPE III**  
(KERLOW STEEL FLOORING CO.)  
(RELIANCE STEEL PRODUCTS CO.)

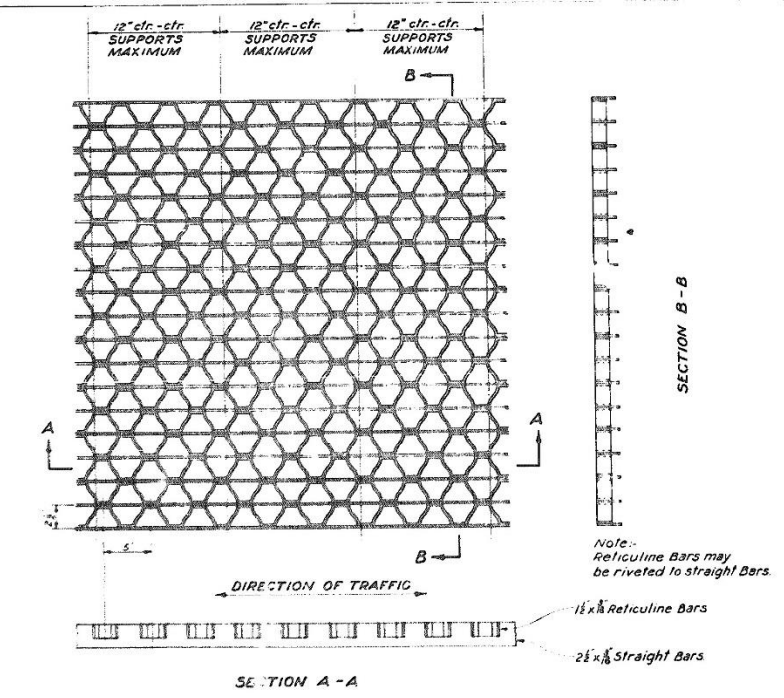

**BRIDGE FLOORING TYPE IV**  
(IRVING IRON WORKS CO.)  
(RELIANCE STEEL PRODUCTS CO.)  
(KERLOW STEEL FLOORING CO.)

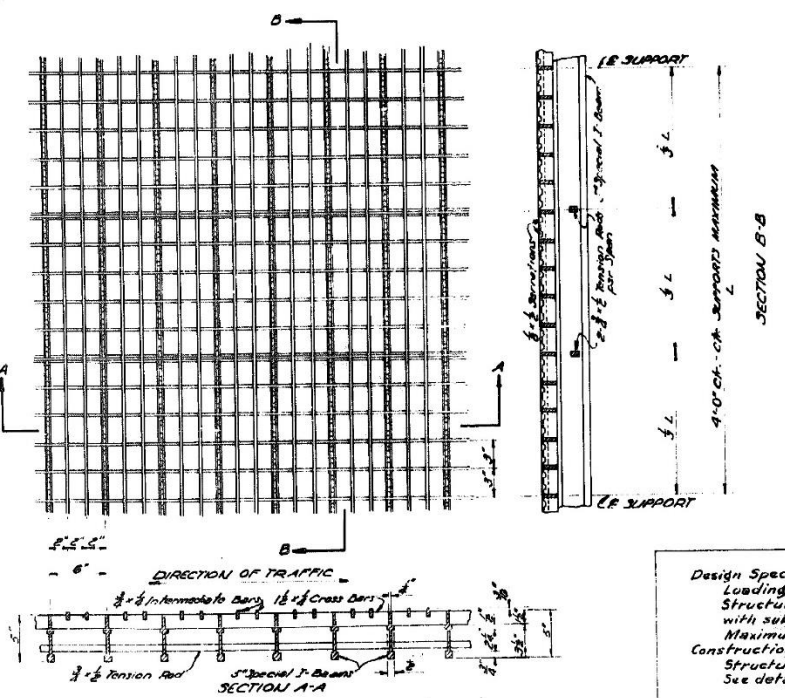

**BRIDGE FLOORING TYPE V**  
(KERLOW STEEL FLOORING CO.)

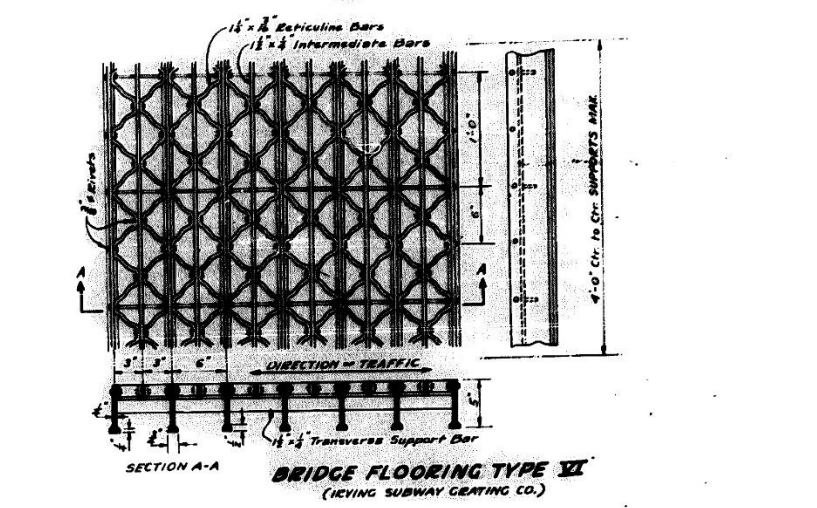

**BRIDGE FLOORING TYPE VI**  
(IRVING SUBWAY GRATING CO.)

Design Specifications: A.A.S.H.O., 1949 with amendments of Dec. 1950  
Loading H15-S12 or H20-S16  
Structural Carbon Steel: A.S.T.M. A-7-42, Rivets A.S.T.M. A-141-42  
with subsequent Amendments.  
Maximum allowable fibre stress = 18,000  $\psi$   
Construction Specifications: Latest La. Hwy. Dept. Std. Specifications.  
Structural Steel shall be not less than  $\frac{3}{8}$  in thickness.  
See detail of span for type of flooring to be used.

STANDARD PLAN  
OPEN GRID BRIDGE FLOORING

DATED 1-24-1946

STATE OF LOUISIANA  
DEPARTMENT OF HIGHWAYS

DESIGNED	BY	TRACED	BY
CHECKED	BY	CHECKED	BY
IN CHARGE OF	BY	HEAD	BY

FINAL TRACINGS







///

NO.	REV.	DATE	BY

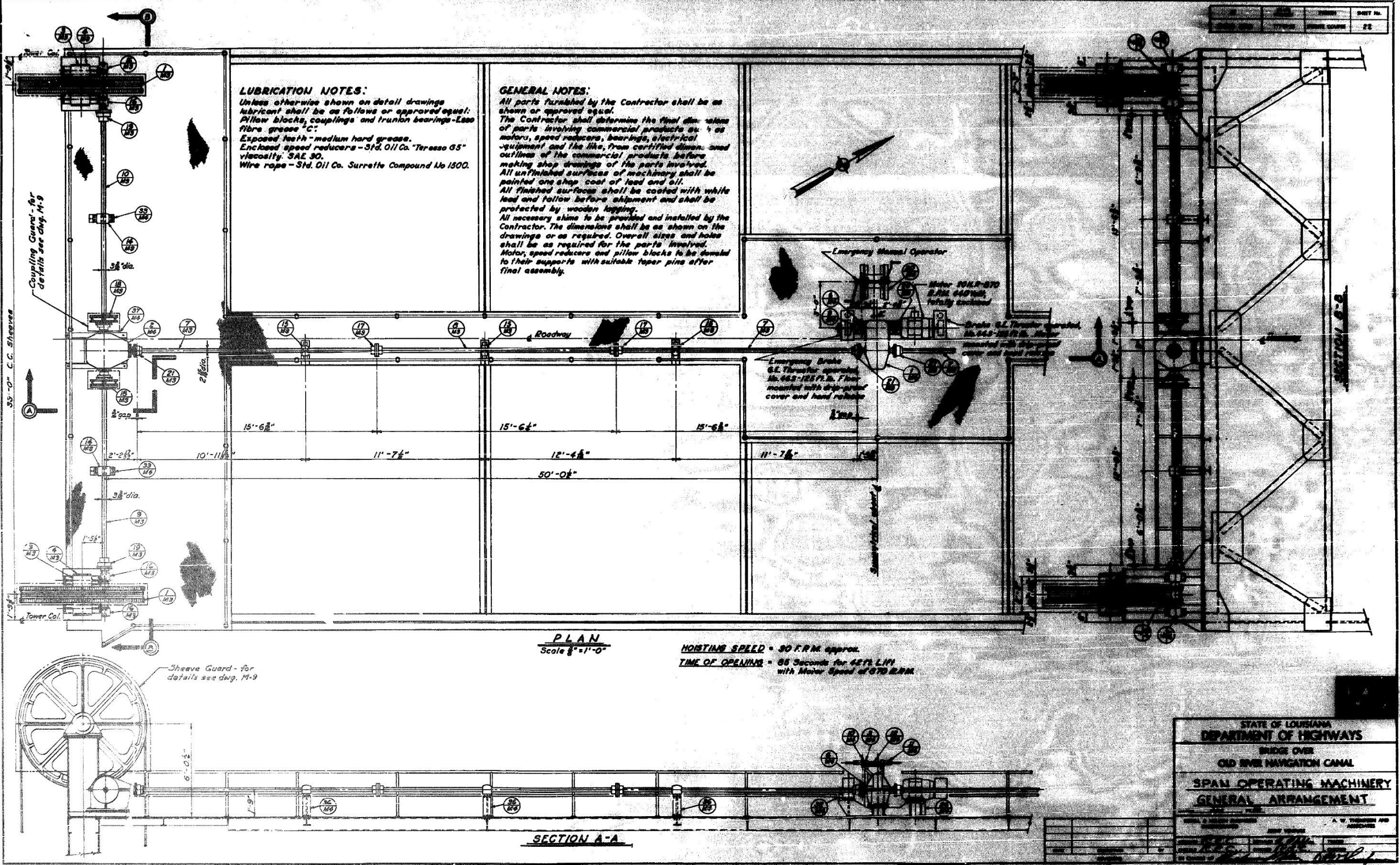

FINAL TRACINGS



116

NO.	DATE	BY	CHKD. BY
27	11/28/52	W. W. THOMPSON	A. W. THOMPSON AND ASSOCIATES

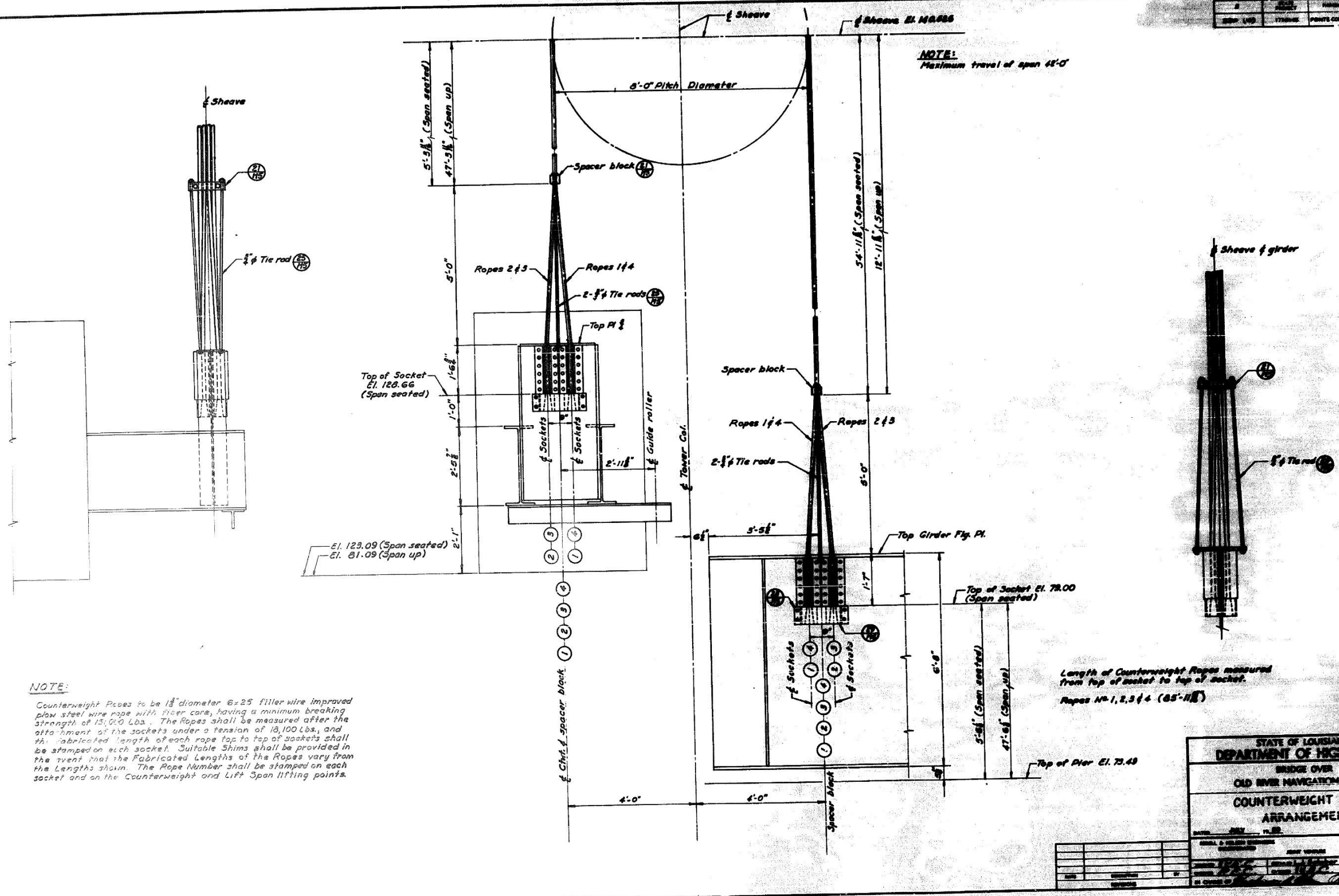

**NOTE:**  
Maximum travel of span 48'-0"

**NOTE:**  
Counterweight Ropes to be 1 3/8" diameter 6x25 filler wire improved plain steel wire rope with fiber core, having a minimum breaking strength of 15,000 Lbs. The Ropes shall be measured after the attachment of the sockets under a tension of 10,000 lbs., and the fabricated length of each rope top to top of sockets shall be stamped on each socket. Suitable Shims shall be provided in the event that the fabricated lengths of the Ropes vary from the lengths shown. The Rope Number shall be stamped on each socket and on the Counterweight and Lift Span lifting points.

Length of Counterweight Ropes measured from top of socket to top of socket.  
Ropes No. 1, 2, 3 & 4 (85'-11 1/2")

**M5**

STATE OF LOUISIANA  
**DEPARTMENT OF HIGHWAYS**  
BRIDGE OVER  
OLD RIVER NAVIGATION CANAL  
**COUNTERWEIGHT ROPES  
ARRANGEMENT**

DATE: 11/28/52

DESIGNED BY: W. W. THOMPSON  
CHECKED BY: A. W. THOMPSON AND ASSOCIATES



FINAL TRACINGS

**Appendix C. 2014 Maintenance Agreement between the USACE  
and LADOTD**

**THIS PAGE INTENTIONALLY LEFT BLANK**

**AMENDED MEMORANDUM OF AGREEMENT**  
between the  
**UNITED STATES ARMY CORPS OF ENGINEERS**  
and the  
**LOUISIANA DEPARTMENT OF TRANSPORTATION AND DEVELOPMENT**  
**OLD RIVER LOCKS MAINTENANCE**

This agreement, entered into this 29<sup>th</sup> day of September, 2014 by the UNITED STATES of AMERICA, (hereinafter called the Government) represented by the District Engineer executing this Agreement, and the STATE OF LOUISIANA, DEPARTMENT OF TRANSPORTATION AND DEVELOPMENT, or its successor or assigns, (hereinafter called the Department) represented by its District Administrator, for operation and maintenance of the vertical lift highway bridge across Old River Navigation Lock Pointe Coupee Parish, Louisiana, by the Government with reimbursement by the Louisiana Department of Transportation and Development.

**WITNESSETH THAT:**

WHEREAS, on July 2, 1962 Contract No. DA-16-047-CIVVENG-63-22, a tripartite agreement between the Department of the Army, Corps of Engineers; the State of Louisiana, Department of Highways; and the Department of Commerce, Bureau of Public Roads was entered into, which provides for cost participation of highway facilities consisting of a vertical lift bridge over and across the Old River Navigation Lock; and

WHEREAS, on February 25, 1965 Contract No. DA-16-047-CIVVENG-65-55, a bipartite agreement between the United States of America and the State of Louisiana, Department of Transportation and Development was entered into, which provides for operations and maintenance of the vertical lift highway bridge across Old River Navigation Lock, Pointe Coupee Parish, Louisiana by the Government with reimbursement by the Department of Transportation and Development; and

WHEREAS, the physical and economic circumstances of the operation and maintenance of the bridge has changed since the parties entered into the February 25, 1965 agreement, and the parties desire to amend the said agreement to better provide for the reimbursement by the Department, by deleting those provisions in their entirety and substituting these provisions in their place;

**NOW, THEREFORE,** the parties hereto do mutually agree as follows:

**ARTICLE I. Obligations of the Government.**

- a. The Government shall operate and maintain the vertical lift bridge for the Department on a reimbursable basis. The vertical lift bridge is defined as the complete vertical lift bridge facility, including lighting and controls, traffic barriers and gates, video cameras and supports that are required by necessity to be located beyond the locks walls for proper control of both the highway and marine traffic during the operation of the vertical lift bridge. The approach spans are not included. The bridge is shown on drawing titled "Old River Control, La.", August 1962, file No. K-124-20335/3. The bridge will be operated as necessary to provide a minimum of interference with both highway and waterborne traffic.
- b. The Government will maintain on a reimbursable basis the vertical lift bridge and appurtenances, including machinery, electrical equipment, signals, safety devices, lighting and closed circuit video system in good working order, clean and make necessary adjustments to mechanical and electrical equipment and make minor and major repairs as required.
  1. Minor repairs shall be those whose costs do not exceed three thousand dollars (\$3,000.00). Concurrence of the District Administrator will be secured prior to making major repairs of alterations, except in case of an emergency.
  2. The term "major repairs" as used in this agreement is hereby defined to mean the renewal of, replacement of, or repairs to the whole of any parts of the said vertical lift bridge and appurtenances, more specifically described above, not occasioned by or due to the negligence of the Government, its servants, agents or employees, in excess of three thousand dollars (\$3,000.00) for any single item (which shall be deemed to include all component parts of such items) of renewal, replacement or repairs to said vertical lift bridge and appurtenances which, in the opinion of the District Engineer or his representative, can no longer be kept in a safe, suitable and dependable operating condition by the performance of usual maintenance and repairs, comparable to those provided for and performed on like or similar property, structures, equipment and facilities owned, operated and maintained by the Government.

- i. Said major repairs shall be performed by the District Engineer or his representative for and on account of the Department, and the cost thereof shall be applied to the operation and maintenance accruing under this agreement or, at the option of the Government, shall be billed to the Department and payment made by the Department at the end of the month in which the account is rendered.
- ii. Notice shall be given the Department from time to time of any contemplated major repairs, and such repairs shall not be made until the Department, through its District Administrator or its designated Appointee, has given approval within a period of fifteen days (15) from date of notification.
- iii. The District Engineer may determine that an emergency exists and such repairs are urgent and necessary for the continuing satisfactory operations of the bridge and in the interest of public safety. In the event of an emergency, the District Engineer shall notify the District Administrator by telephone and/or email giving the nature of the emergency and procedures being undertaken to restore the bridge.

**ARTICLE II. Obligations of the Department**

- a. The Department shall be responsible for and shall reimburse the Government for all costs expended in connection with the operation and maintenance of the vertical lift bridge and appurtenances, major and minor repairs provided in Article I hereof, such costs to include all items of expense properly chargeable thereto, including, but not limited to, painting, labor, materials, transportation, overheard charges properly allocable to operation and maintenance, supervision, rental of tools, equipment and machinery employed in the operation and maintenance, together with such other items of expense which should, in the opinion of the District Engineer, be included in the cost of operation and maintenance.
- b. Payment for operating and maintaining the vertical lift bridge and appurtenances is estimated to be the salary and other budgetary burdens of one WY-9/5 Lock Operator plus an advance sum for minor repairs per annum. The estimated operation and maintenance costs accruing under this agreement will be paid to the Government semiannually in advance by the Department.

- c. The Department shall contribute semi-annually in advance, one-half of the estimated cost of operating and maintaining the vertical lift bridge, which contribution shall be for the purpose of providing a semi-annual advance payment sum to meet obligations of the Department, provided that, by mutual agreement this lump sum advance payment may be increased, or decreased; to provide the minimum sum required to meet the semi-annual obligations of the Department. At the end of each month, final settlement for that month will be made on the basis of an audit report of records maintained by the Government, a certified true copy of which will be furnished to the Department. At the end of the six month period, any excess will be deducted from and any deficiency will be added to the advance contribution for the following six month period.

**ARTICLE III. Period of Services.**

The period of services under this Agreement shall be a fiscal year basis (1 July – 30 June) and shall automatically renew annually, unless terminated by mutual agreement of the parties hereto.

**ARTICLE IV. District Engineer's Decision.**

The extent and character of the operation and maintenance to be done by the Government shall be subject to the approval of the Department. In the event there should be any dispute with regard to the operation and maintenance to be done, the decision of the District Engineer shall govern, but the Department shall have the right of appeal as provided below.

**ARTICLE V. Disputes.**

- a. Except as otherwise provided in this contract, any dispute concerning a question of fact arising under this contract which is not disposed of by agreement shall be decided by the District Engineer, who shall produce his decision in writing and mail or otherwise furnish a copy thereof to the Department. The decision of the District Engineer shall be final and conclusive unless, within 30 days from the date of receipt of such copy, the Department mails or otherwise furnishes to the District Engineer a written appeal addressed to the Secretary. The decision of the Secretary or his duly authorized representative for the determination of such appeals shall be final and conclusive unless determined by a court of competent jurisdiction to have been



fraudulent, or capricious, or arbitrary, or so grossly erroneous as necessarily to imply bad faith, or not supported by substantial evidence. In connection with any appeal proceeding under this clause, the Department shall be afforded an opportunity to be heard and to offer evidence in support of its appeal. Pending final decision of a dispute hereunder, the Department shall proceed diligently with the performance of the contract and in accordance with the District Engineer's decision.

- b. This "Disputes" clause does not preclude consideration of law questions in connection with decisions provided for in paragraph a. above: Provided that nothing in this contract shall be construed as making final the decision of any administrative official, representative, or board on a question of law.

#### **ARTICLE VI. Covenant Against Contingent Fees.**

The Department warrants that no person or selling agency has been employed or retained to solicit or secure this agreement upon an agreement or understanding for a commission, percentage, brokerage, or contingent fee, excepting bona fide employees or bona fide established commercial or selling agencies maintained by the Department for the purpose of securing business. For breach or violation of this warranty the Government shall have the right to annul this agreement without liability or in its discretion to deduct from the agreement price or consideration or otherwise recover the full amount of such commission, percentage, brokerage, or contingent fee.

#### **ARTICLE VII. Officials Not to Benefit.**

No member or delegate to Congress, or resident commissioner, shall be admitted to any share or part of this agreement, or to any benefit that may arise therefrom; but this provision shall not be construed to extend to this agreement if made with a corporation for its general benefit.

#### **ARTICLE VIII. Definitions.**

- a. The term "head of the agency" or "Secretary" as used herein means the Secretary of the Army; the term "his duly authorized representative" means the Chief of Engineers, Department of the Army, or an individual or board designated by him.

- b. The term "District Engineer" as used herein means the person executing this contract on behalf of the Government and includes a duly appointed successor or authorized representative.

IN WITNESS WHEREOF, the parties hereto have executed this agreement as of the day and year first above written.

WITNESSES:

*Sandra P. Habbaz*  
(sign)

SANDRA P. HABBAZ  
(print)

*Amy J. Hawkins*  
(sign)

Gary L. Hawkins  
(print)

*Patrice Little*  
(sign)

Patrice Little  
(print)

*Cassandra D. Gray*  
(sign)

Cassandra D. Gray  
(print)

THE UNITED STATES OF AMERICA

BY: *Richard L. Hansen*  
Richard L. Hansen  
Colonel, U.S. Army  
District Engineer

STATE OF LOUISIANA, Department of  
Transportation and Development

BY: *R. Kirk Gallien*  
R. Kirk Gallien, P.E., P.T.O.E.  
Deputy Asst. Secretary of Operations  
(title)

**ATTORNEY'S CERTIFICATE OF AUTHORITY**

I, Darlene M. Major, Attorney for the State of Louisiana, certify that R. Kirk Gallien, P.E., P.T.O.E., the Deputy Assistant Secretary of Operations for the Department of Transportation and Development, has the authority to enter into the above Amended Memorandum of Agreement for the operation and maintenance of the vertical lift highway bridge across the Old River Navigation Lock Pointe Coupee Parish, Louisiana; that said Amended Memorandum of Agreement is executed by the proper duly-authorized officer; and that the Amended Memorandum of Agreement is in sufficient form to grant the authorization for and rights therein stated.

Witness my signature as Attorney for the State of Louisiana this 28<sup>th</sup> day of August 2014.

BY: Darlene M. Major  
(sign)

Darlene M. Major  
(print)

Attorney for the State of Louisiana

### ATTORNEY'S CERTIFICATE OF AUTHORITY

I, Marco Rosamano, Assistant District Counsel, New Orleans District, U.S. Army Corps of Engineers, certify that Colonel Richard L. Hansen, District Engineer, New Orleans District, U.S. Army Corps of Engineers, has the authority to enter into the above Amended Memorandum of Agreement for the operation and maintenance of the vertical lift highway bridge across the Old River Navigation Lock, Pointe Coupee Parish, Louisiana; that said Amended Memorandum of Agreement is executed by the proper duly-authorized officer; and that the Amended Memorandum of Agreement is in sufficient form to grant the authorization for and rights therein stated.

Witness my signature as Attorney for the State of Louisiana this 25<sup>th</sup> day of September 2014.

BY: Marco Rosamano  
Marco Rosamano  
Assistant District Counsel  
New Orleans District  
U.S. Army Corps of Engineers

**OLD RIVER LOCK  
VERTICAL LIFT BRIDGE  
2014/2015 ESTIAMTE OF  
OPERATION AND MAINTENANCE COSTS**

The bridge will be operated by lock operators. Maintenance such as cleaning, lubrication and adjustment of machinery, electrical equipment, signals, safety devices, lighting and closed circuit television system, will be performed by lock operators. In lieu of maintaining records of time spent in the above activities, one full time lock operator will be charged to bridge operation and maintenance at established rates. Current established rates are shown below. Labor for both minor and majors repairs will be charged on the basis of records maintained of actual time required for the repairs. An estimate of those annual costs is also shown below.

1. WY-9/5 Lock Operator	\$110,000.00
Includes overhead and leave burden	
2. Minor Repairs & Parts	\$10,000.00
<hr/>	
Current Estimated Annual Cost	\$120,000.00

**THIS PAGE INTENTIONALLY LEFT BLANK**